

# Leica RoadRunner Rail Technical Reference Manual



Version 2.0  
English

- when it has to be **right**

**Leica**  
Geosystems

# Introduction

## Purchase

Congratulations on the purchase of a RoadRunner Rail application.



To use the product in a permitted manner, please refer to the detailed safety directions in the User Manual.

## Product identification

The type and serial number of your product are indicated on the type plate. Enter the type and serial number in your manual and always refer to this information when you need to contact your agency or Leica Geosystems authorized service workshop.

Type: \_\_\_\_\_

Serial No.: \_\_\_\_\_

## Symbols

The symbols used in this manual have the following meanings:

| Type  | Description  |
|---|--|
|  | Important paragraphs which must be adhered to in practice as they enable the product to be used in a technically correct and efficient manner. |

## Trademarks

- Windows and Windows CE are a registered trademark of Microsoft Corporation
  - CompactFlash and CF are trademarks of SanDisk Corporation
  - Bluetooth is a registered trademark of Bluetooth SIG, Inc
- All other trademarks are the property of their respective owners.

## This manual is for GPS1200 receivers and TPS1200 instruments

### GPS1200 receivers

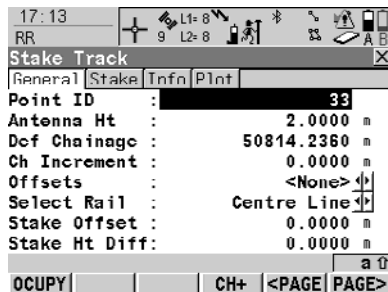

The following keys refer to GPS1200:  
OCUPY (F1), STOP (F1), STORE (F1).  
They all have the same functionality in all  
manuals which refer to GPS1200 products.

#### **OCUPY (F1)**

To start measuring the point.

#### **STOP (F1)**

To end measuring the point.

#### **STORE (F1)**

To record/store the measured point.

### TPS1200 instruments

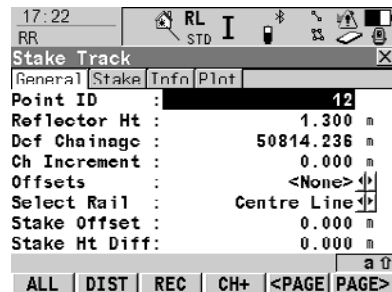

The following keys refer to TPS1200:  
ALL (F1), DIST (F2), REC (F3).  
They all have the same functionality in all  
manuals which refer to TPS1200 products.

#### **ALL (F1)**

To measure/record distances and angles.

#### **DIST (F2)**

To measure and display distances.

#### **REC (F3)**

To record/store the measured data.

# Table of Contents

In this manual

| Chapter   | Page      |
|---|-----------|
| <b>1 Getting Started with RoadRunner Rail</b>                     | <b>7</b>  |
| 1.1 Part A) Installing all of the necessary Software              | 7         |
| 1.2 Part B) Importing the Track Design with LEICA Geo Office      | 8         |
| 1.3 Part C) Loading the Track Design onto the Receiver/Instrument | 13        |
| 1.4 Part D) Turning on the Receiver/Instrument and Starting Rail  | 14        |
| 1.4.1 RoadRunner Begin  | 17        |
| 1.4.2 RoadRunner Rail Setup                                       | 19        |
| <b>2 Checking a Track with Rail Check</b>                         | <b>21</b> |
| 2.1 Step 1) Positioning the Receiver (for GPS only)               | 21        |
| 2.2 Step 2) Positioning the Instrument (for TPS only)             | 22        |
| 2.3 Step 3) Selecting Rail Check                                  | 24        |
| 2.4 Step 4) Creating/Selecting a Task                             | 25        |
| 2.5 Step 5) Checking the Track                                    | 26        |
| 2.6 Step 6) Using Offsets   | 29        |
| 2.7 Step 7) Using the Extras Menu                                 | 34        |
| <b>3 Setting out a Track with Rail Stake-Out</b>                  | <b>38</b> |
| 3.1 Step 1) Positioning the Receiver (for GPS only)               | 38        |
| 3.2 Step 2) Positioning the Instrument (for TPS only)             | 39        |
| 3.3 Step 3) Selecting Rail Stake-Out                              | 41        |
| 3.4 Step 4) Creating/Selecting a Task                             | 42        |
| 3.5 Step 5) Setting Out the Track                                 | 43        |
| 3.6 Step 6) Understanding the Stake Pages                         | 49        |
| 3.7 Step 7) Using Offsets   | 51        |

|          |   |           |
|----------|---|-----------|
| 3.8      | Step 8) Using the Extras Menu                           | 56        |
| <b>4</b> | <b>Managing your Projects and Jobs</b>                  | <b>58</b> |
| 4.1      | Overview  | 58        |
| 4.2      | Selecting a Project by Browsing a List of Projects      | 62        |
| 4.3      | Selecting a Project by Resuming the Last Task           | 63        |
| 4.4      | Creating a New Project                                  | 64        |
| 4.5      | Editing an Existing Project                             | 65        |
| 4.6      | Deleting an Existing Project                            | 67        |
| <b>5</b> | <b>Managing the Rail Job</b>                            | <b>68</b> |
| 5.1      | Overview  | 68        |
| 5.2      | Working with the Design Data                            | 69        |
| 5.3      | Working with the Tasks                                  | 71        |
| 5.4      | Viewing and Editing the Design Data                     | 77        |
|          | 5.4.1 Overview  | 77        |
|          | 5.4.2 Viewing the Design Data                           | 79        |
|          | 5.4.3 Editing the Design Data                           | 85        |
| <b>6</b> | <b>Configuring</b>                                      | <b>87</b> |
| 6.1      | Overview of all Configuration Settings                  | 87        |
| 6.2      | Configuration Settings for the Project - Project Config | 88        |
|          | 6.2.1 The General Page                                  | 88        |
|          | 6.2.2 The Posit Page (TPS only)                         | 91        |
| 6.3      | Configuration Settings for the Program - Rail Config    | 93        |
|          | 6.3.1 The General Page                                  | 93        |
|          | 6.3.2 The Rail Page                                     | 97        |
|          | 6.3.3 The Check Page                                    | 102       |
|          | 6.3.4 The Info&Plot Page                                | 105       |
|          | 6.3.5 The Logfile Page                                  | 113       |

|              |  |            |
|--------------|--|------------|
| 6.4          | Auto Positioning (TPS only)                        | 114        |
| 6.4.1        | Overview (TPS only)                                | 114        |
| 6.4.2        | Auto Position 2D + Measure (TPS only)              | 116        |
| 6.4.3        | Auto Position Advanced (TPS only)                  | 118        |
| <b>7</b>     | <b>Using Rail Editor for Superelevation</b>        | <b>120</b> |
| <b>8</b>     | <b>Understanding the Terms and Expressions</b>     | <b>125</b> |
| 8.1          | Overview   | 125        |
| 8.2          | Working with a Single Track                        | 127        |
| 8.3          | Working with Multiple Tracks                       | 130        |
| 8.4          | Rail Check Elements and Rail Stake-Out Elements    | 132        |
| 8.5          | Working with Offsets                               | 134        |
| 8.6          | Working with Horizontal Shifts and Vertical Shifts | 135        |
| <b>Index</b> |  | <b>138</b> |

# 1 Getting Started with RoadRunner Rail

## 1.1 Part A) Installing all of the necessary Software

- 
- |   |   |
|---|---|
| <b>Install LEICA Geo Office</b>               | <ul style="list-style-type: none"><li>• LGO runs under Windows2000 or WindowsXP and can only be installed successfully if the user is logged in as the Administrator. To install LGO, run the LAUNCH.EXE from the CD Rom and follow the instructions on the screen.</li></ul>   |
| <hr/>   |   |
| <b>Install Design To Field</b>                | <ul style="list-style-type: none"><li>• To successfully prepare the track design for use on the receiver/instrument, the data must first be converted from its original format to an on-board job. This is achieved using 'Design to Field', a component of LGO which is automatically installed with LGO.</li></ul>  |
| <hr/>   |   |
| <b>Install Importers</b>                      | <ul style="list-style-type: none"><li>• The field importers are used by 'Design to Field' to read in the track design. These importers are installed separately and have the file extension *.rri.</li><li>• The latest version of the Design to Field importers may be found in the downloads section of the Leica Geosystems website:<br/><a href="http://www.leica-geosystems.com/s-e/en/downloads/lgs_page_catalog.htm?cid=3291">http://www.leica-geosystems.com/s-e/en/downloads/lgs_page_catalog.htm?cid=3291</a></li></ul> |
| <hr/>   |   |
| <b>Install Rail Editor</b>                    | <ul style="list-style-type: none"><li>• Rail Editor is a PC program for defining the height of the rails relative to the horizontal and vertical alignments (superelevation). Rail Editor is automatically installed into LGO from the 'Field Importers' install package, which may be found in the downloads section of the Leica Geosystems website. Rail Editor may be run either externally or within 'Design To Field'.</li></ul>  |
| <hr/>   |   |
| <b>Install RoadRunner and RoadRunner Rail</b> | <ul style="list-style-type: none"><li>• These are the on-board programs which are loaded onto the receiver/instrument:<ul style="list-style-type: none"><li>• via a CF card (under the System folder), which is inserted into the receiver/instrument,</li><li>• via a serial cable and LGO.</li></ul></li></ul>  |
-

## 1.2

### Importing the design

## Part B) Importing the Track Design with LEICA Geo Office



### 1. Starting the 'Design to Field' program.

To import a track centre line select 'Design to Field' from the Tools menu in LGO.

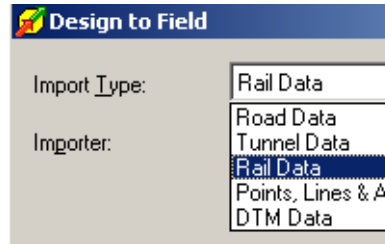

### 2. Selecting an Import Type.

To successfully prepare track design for on-board use it has to be converted from its original data format to an on-board job which will run on the receiver/instrument.

Select Importer Type = 'Rail Data'.

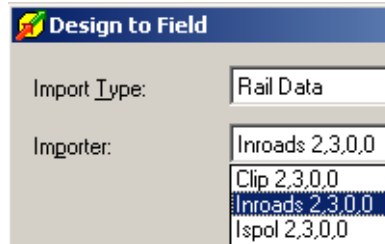

### 3. Selecting a Field Importer.

Importers are used to convert the data. Additional importer formats can be added to the drop-down list by clicking on 'Manage'.

Select the importer related to the track design from the drop-down list of available importers.

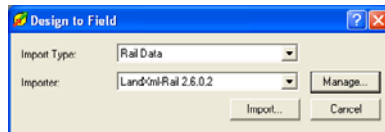

### 4. Importing.

Click 'Import' to start the file selection wizard.



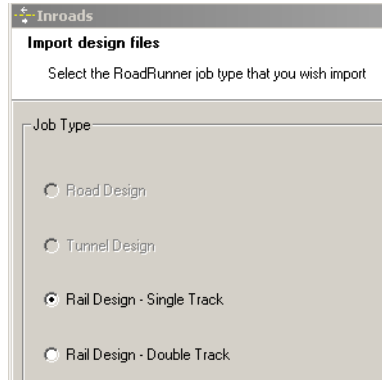

## 5. **Selecting the job type.**

Select the appropriate job type.

For single tracks, select 'Rail Design-Single Track'.  
For double tracks, select 'Rail Design-Double Track'.

A single track design may consist of a horizontal alignment, a vertical alignment and superelevation.

A double track design may consist of a horizontal alignment, a vertical alignment and superelevation for each track. Alternatively, a third horizontal alignment may also be defined and used for calculating the chainage of both tracks (chainage centre line).

Click 'Next' to move to the next page of the wizard.

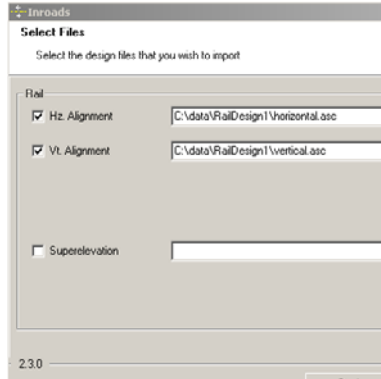

6. **Selecting the horiz and vert alignment files.**  
In the case of a single track, select the horizontal and vertical alignments using the browse buttons.

In the case of a double track, three panels are used to define the design data. The arrows at the bottom of the panel may be used to move between the different panels.

**First Panel: Centre Line**

The first panel defines the horizontal and vertical alignment of the chainage centre line. Note, it is not mandatory to select a chainage centre line, if the chainage for each track is to be calculated relative to each track centre line. Then the horizontal and vertical alignment on the first panel may be left blank.

**Second Panel: Left Track**

The second panel defines the horizontal and vertical alignments and the rail definition (superelevation) of the left track.

**Third Panel: Right Track**

The third panel defines the horizontal and vertical alignments and the rail definition (superelevation) of the right track.

Click 'Next' to move to the next page of the wizard.

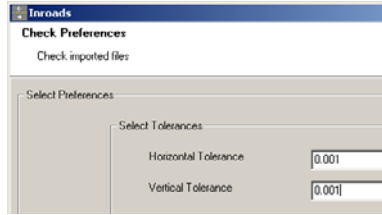

**7. Entering the alignment tolerances.**

Enter the appropriate horizontal and vertical tolerances to be used during the checking of the alignments.

Click 'Next' to move to the next page of the wizard.



**8. Checking the track design.**

When the track design has been imported, information is displayed to show the success or failure of the import.

When the import is successful:

Click 'Next' to move to the next page of the wizard.

When the import is unsuccessful:

Click 'Back' to step back through the wizard.

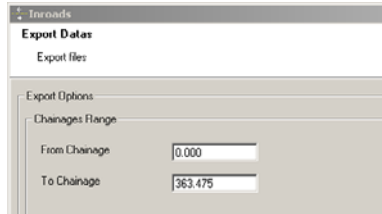

**9. Entering the range of chainages to be used.**

Enter the range of chainages to be exported.

Click 'Next' to move to the next page of the wizard.

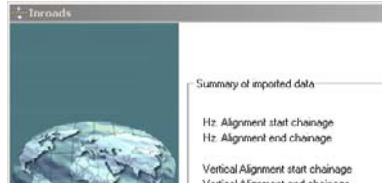

- 10. Checking the summary report.**  
When the report is correct:  
Click 'Finish' to complete the wizard.

When the report is incorrect:  
Click 'Back' to step back through the wizard.

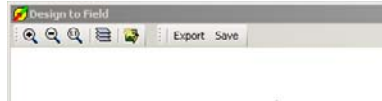

- 11. Viewing the track design.**  
The track design can be viewed graphically.

Click 'Export' to create the files for on-board use.

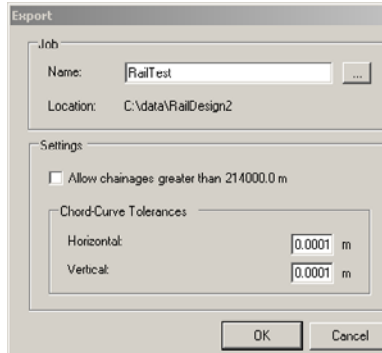

- 12. Creating the files for on-board use.**  
The track design can now be prepared.

Click 'OK' to create the files for on-board use. The database files are created and are located in the same folder as the source alignment files.



### **Design to Field User Manual.**

Refer to the 'Design to Field User Manual' for details on importing various types of data with various field importers. This manual is included in the Design to Field Converters install application 'RR\_Design\_to\_Field.exe', which can be downloaded.

## 1.3

### Loading the design

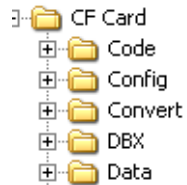

## Part C) Loading the Track Design onto the Receiver/Instrument

---

1. Once the track design has been converted, copy all of the database files to the DBX folder of the CF Card.
-

## 1.4

Start working with an existing project

## Part D) Turning on the Receiver/Instrument and Starting Rail

### 1. Turning on the receiver/instrument.

For GPS: Press the 'PROG' key.

For TPS: Press and hold down the 'PROG' key for 2 s.



### 2. Selecting Programs from the Main Menu.

Select 'Programs' from the Main Menu, or Press the 'PROG' key on the keyboard, or Press a hot key (F7)-(F12), (which has been user-configured), or Press the 'USER' key, (which has been user-configured).

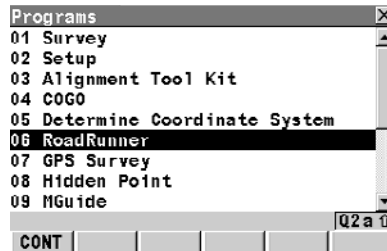

### 3. Selecting the RoadRunner group of programs.

Select 'RoadRunner' from the Programs menu.

This program is licence protected. The program is activated through a specific licence key. This licence key can be entered either under 'Main Menu: Tools...\Licence Keys' or the first time the program is started.

Press 'CONT (F1)' to continue to the next screen.

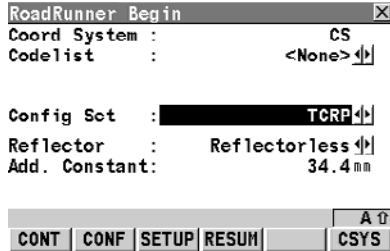

#### 4. General settings.

This screen allows to set up the instrument, to configure RoadRunner, and to continue with the last task.

Press '**CONF (F2)**' to enter the RoadRunner configurations panel. Refer to "6 Configuring" for details.

Press '**SETUP (F3)**' to set up the instrument. Refer to the System 1200 manual for details.

Press '**RESUM (F4)**' to continue with the last used task. Refer to "5.3 Working with the Tasks" for details.

Press '**CSYS (F6)**' to select a coordinate system. Refer to the System 1200 manual for details.

Press '**CONT (F1)**' to continue to the next screen.

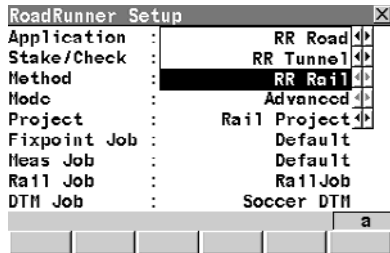

#### 5. Selecting the RR Rail program.

Select the application "RR Rail". This line will only be shown if there are other RoadRunner applications are installed also.

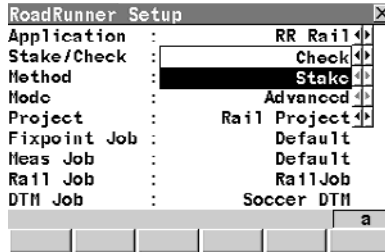

**6. Selecting either 'Rail Check' or 'Rail Stake-Out'.**

For check surveys, select 'Rail Check'.

Refer to "2 Checking a Track with Rail Check" for details on check surveys.

For set out surveys, select 'Rail Stake-Out'.

Refer to "3 Setting out a Track with Rail Stake-Out" for details on set out surveys.

Press 'CONF (F2)' to access configuration settings. Refer to "6 Configuring" for details.

Press 'CONT (F1)' to continue to the next screen.

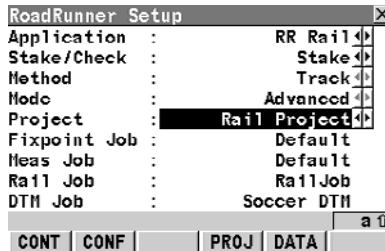

**7. Selecting a project.**

Select a project or press ENTER to go to the projects panel. Refer to "4 Managing your Projects and Jobs" for details.

Press '**CONT (F1)**' to continue to the next screen.



## 1.4.1

### RoadRunner Begin

#### Positioning the TPS

#### This screen shows the following:

To select the coordinate system, codelist, configuration set and reflector for the survey.

The screenshot shows a terminal window titled "RoadRunner Begin" with a close button (X) in the top right corner. The screen displays the following configuration options:

- Coord System : CS
- Codelist : <None> (with up/down arrow icons)
- Config Sct : TCRP (with up/down arrow icons)
- Reflector : Reflectorless (with up/down arrow icons)
- Add. Constant: 34.4 mm

At the bottom of the screen, there is a navigation bar with several buttons: CONT, CONF, SETUP, RESUM, and CSYS. The CSYS button is highlighted with a cursor (A ↑).

#### CONT (F1)

To continue to the next screen.

#### CONF (F2)

To access the configuration settings.  
Refer to "6 Configuring" for details.

#### SETUP (F3)

To set up an instrument station by determining the station coordinates and orienting the horizontal circle.

#### RESUM (F4)

To resume the last used and stored task. This is a recommended feature when using Advanced mode.

#### CSYS (F6)

To change the current coordinate system.

| <b>Field</b>         | <b>Description of Field</b>   |
|----------------------|---|
| <b>Coord System</b>  | Output. The active coordinate system. Use CSYS (F6) to change the coordinate system.<br><br>Rail jobs are defined in local grid coordinates. The right coordinate system must be chosen for the rail job. |
| <b>Codelist</b>      | Choicelist. The active codelist. All codelists from Main Menu: Manage...\Codelists can be selected.   |
| <b>Config Set</b>    | Choicelist. The active configuration set. All configuration sets from Main Menu: Manage...\Configuration Sets can be selected.  |
| <b>Reflector</b>     | Choicelist. The reflector currently set in the selected configuration set. All reflectors from 'Main Menu: Manage...\Reflectors' may be selected.   |
| <b>Add. Constant</b> | Output. The additive constant stored with the chosen reflector.   |

## 1.4.2

## RoadRunner Rail Setup

### RoadRunner Setup

This screen shows the following:

An overview of the setup information selected for the survey.

```
RoadRunner Setup
Application : RR Rail
Stake/Check : Stake
Method      : Track
Mode       : Advanced
Project    : Rail Project
Fixpoint Job : Default
Meas Job   : Default
Rail Job   : RailJob
DTM Job    : <None>
```

#### CONT (F1)

To continue to the next screen.

#### CONF (F2)

To access the configuration settings.

Refer to "6 Configuring" for details.

#### PROJ (F4)

To edit the currently selected project.

Refer to "4 Managing your Projects and Jobs".

#### DATA (F5)

To view/edit the data in the rail job.

Refer to "5.4 Viewing and Editing the Design Data".

| Field              | Description of Field  |
|--------------------|---|
| <b>Application</b> | To select the relevant program. This field lists all of the programs that have been loaded into the RoadRunner group. Ensure that RR Rail is selected.<br><pre>RoadRunner Setup Application : RR Road Stake/Check : RR Tunnel Method      : RR Rail</pre> |
| <b>Stake/Check</b> | To select either Stake or Check for the survey.<br><pre>RoadRunner Setup Application : RR Rail Stake/Check : Check Method      : Stake</pre>  |

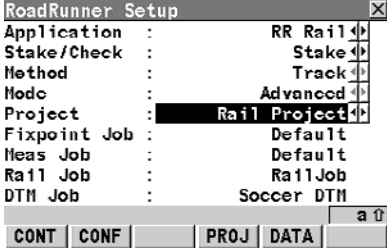
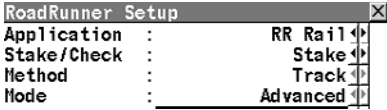
| Field                                  | Description of Field  |
|--|---|
| <b>Method</b>                          | <p>To select the relevant method for the survey. The method is set to Track and can not be changed.</p>  <p>The screenshot shows the 'RoadRunner Setup' dialog box with the following settings: Application: RR Rail, Stake/Check: Stake, Method: Track, Mode: Advanced, Project: Rail Project, Fixpoint Job: Default, Meas Job: Default, Rail Job: RailJob, DTM Job: Soccer DTM. The 'Method' dropdown is highlighted.</p> |
| <b>Mode</b>                            | <p>Set to Advanced automatically and can not be changed in RoadRunner Rail.</p>  <p>The screenshot shows the 'RoadRunner Setup' dialog box with the following settings: Application: RR Rail, Stake/Check: Stake, Method: Track, Mode: Advanced, Project: Rail Project, Fixpoint Job: Default, Meas Job: Default, Rail Job: RailJob, DTM Job: Soccer DTM. The 'Mode' dropdown is highlighted.</p>                           |
| <b>Project</b>                         | To select the relevant project for the survey.  |
| <b>Fixpoint Job</b>                    | The fixpoint job, as defined by the project.  |
| <b>Meas Job</b>                        | The measure job, as defined by the project.   |
| <b>Rail job</b>                        | The rail job, as defined by the project.  |
| <b>DTM (Digital Terrain Model) Job</b> | The DTM job, as defined by the project.   |

## 2

### 2.1

#### Positioning the sensor

## Checking a Track with Rail Check

### Step 1) Positioning the Receiver (for GPS only)

```
RoadRunner Begin
Coord System : WGS 1984
Codelist      : <None>
Config Set    : DEFAULT
Antenna       : AX1202 Pole

CONT  CONF  RESUM  CSYS
```

Once the task has been defined and selected, the receiver can be set.

Select the necessary coordinate system, codelist, configuration set and antenna for the survey. All stake-out methods and check methods share this common screen.

It is possible to skip this screen. Refer to "6 Configuring" for configurations.

#### **CONT (F1)**

To continue to the next screen.

#### **CONF (F2)**

To access the configuration settings.

Refer to "6 Configuring" for configurations.

#### **RESUM (F4)**

To resume the last task running of the high-lighted project. The project to which the task belongs to is selected automatically.

#### **CSYS (F6)**

To change the current coordinate system.

Press 'CONT (F1)' to continue to the next screen.

## 2.2

### Step 2) Positioning the Instrument (for TPS only)

#### Positioning the sensor

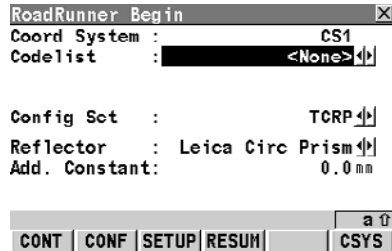

RoadRunner Begin

Coord System : CS1

CodeList : <None>

Config Set : TCRP

Reflector : Leica Circ Prism

Add. Constant: 0.0 mm

CONT CONF SETUP RESUH CSYS

Once the task has been defined and selected, the instrument can be positioned and oriented. This screen allows the instrument position to be established.

Select the necessary coordinate system, codelist, configuration set and reflector for the survey. All stake-out methods and check methods share this common screen.

It is possible to skip this screen.  
Refer to "6 Configuring" for configurations

#### **CONT (F1)**

To continue to the next screen.

#### **CONF (F2)**

To access the configuration settings.

Refer to "6 Configuring" for configurations.

#### **SETUP (F3)**

To allow the station coordinates and orientation to be entered or calculated.

**RESUM (F4)**

To resume the last task running of the highlighted project. The project to which the task belongs to is selected automatically.

**CSYS (F6)**

To change the current coordinate system.

Press 'CONT (F1)' to continue to the next screen.

---

## 2.3

### Step 3) Selecting Rail Check

#### Selecting Check

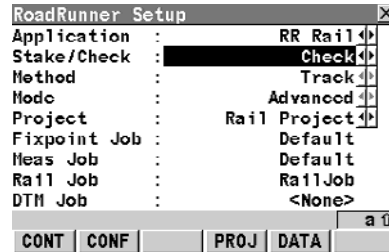

1. Refer to "1 Getting Started with RoadRunner Rail" for details on starting check surveys.

2. Select 'Check' and 'Track'.

Press 'CONF (F2)' to access configuration settings. Refer to "6 Configuring" for configurations.

Press 'CONT (F1)' to continue to the next screen.



## 2.4

### Creating/Selecting a task

## Step 4) Creating/Selecting a Task

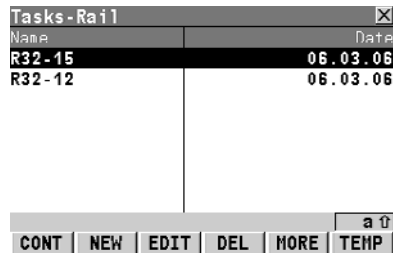

The screenshot shows a window titled "Tasks - Rail" with a table of tasks. The table has two columns: "Name" and "Date". The first row is highlighted in black and contains "R32-15" and "06.03.06". The second row contains "R32-12" and "06.03.06". Below the table is a menu bar with buttons for "CONT", "NEW", "EDIT", "DEL", "MORE", and "TEMP". A cursor is positioned over the "TEMP" button.

| Name   | Date     |
|--------|----------|
| R32-15 | 06.03.06 |
| R32-12 | 06.03.06 |

CONT NEW EDIT DEL MORE TEMP

In order to check a track, a task needs to be created or selected. The task defines which track is to be checked and it also defines any shifts that are to be used during the check survey.

This screen lists already defined tasks.

Refer to "5.3 Working with the Tasks" for details on creating/selecting tasks.

#### **CONT (F1)**

To continue to the next screen.

#### **NEW (F2)**

To create a new task.

#### **EDIT (F3)**

To edit the selected task.

#### **DEL (F4)**

To delete the selected task.

#### **MORE (F5)**

To toggle between date and time info.

#### **TEMP (F6)**

To create a temporary task. This task is identical to any other task but is not stored for later use.

Press 'CONT (F1)' to continue to the next screen.

## 2.5

### Step 5) Checking the Track

#### The General page

| Check Track    |             |
|----------------|-------------|
| General        | Info        |
| Point ID :     | 0001        |
| Reflector Ht : | 1.250 m     |
| Select Rail :  | Centre Line |
| Check Offset : | 0.000 m     |
| Check Ht Diff: | 0.000 m     |
| Ht LowerRail : | ----- m     |
| Cant Left :    | 0 mm        |
| Cant Right :   | 0 mm        |
| Q2 a           |             |
| ALL            | DIST        |
| REC            | <PAGE       |
|                | PAGE>       |

Information regarding the measured point may be entered in the 'General' page. This screen allows any point of the track to be checked against design values.

#### Point ID

The point ID of the point about to be recorded.

#### GPS Antenna Ht

The antenna height.

#### TPS Reflector Ht

The reflector height.

#### Select Rail

The measured point values may be compared with the left rail, the right rail or the track centre line. The 'Select Rail' choicelist allows the stringline with which measured values should be compared, to be selected. The possible options are:

'Left Rail', 'Right Rail' and 'Centre Line'.

#### Check Offset

Applies a horizontal offset perpendicular to the stringline used for comparing the measured point.

#### Check Ht Diff

Applies a vertical offset to the stringline used for comparing the measured point.

### **Ht LowerRail**

Defines the absolute height of the lowest rail at the defined chainage.



### **Cant Left**

Defines the superelevation at the left rail. If the superelevation is rotated around the left rail, the superelevation would be zero.

This field is only active when 'Use Cant=Yes'. Refer to "6.3 Configuration Settings for the Program - Rail Config" for details on configuration settings.



### **Cant Right**

Defines the superelevation at the right rail. If the track is rotated around the right rail, the superelevation would be zero. The total superelevation (left + right) is applied across the distance defined as the superelevation base in the configuration.

This field is only active when 'Use Cant=Yes'. Refer to "6.3 Configuration Settings for the Program - Rail Config" for details on configuration settings.

Press 'PAGE (F6)' to move to the next page.

---

## The Info page

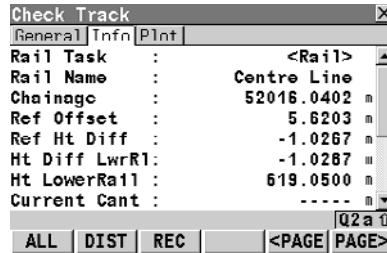

The 'Info' page displays the differences between the measured and design data.

The fields viewed in the 'Info' page may be configured by the user in the 'Info&Plot' page of the configuration settings. Configuration settings may be accessed by pressing SHIFT CONF (F2). Refer to "6 Configuring" for configurations.

Press 'PAGE (F6)' to move to the next page.

## The Plot page

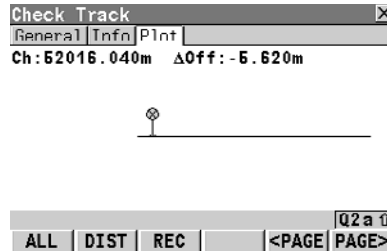

The 'Plot' page displays a plot of the measured point with respect to the track design.

The actual graphical representation shown in the 'Plot' page may be configured by the user in the 'Info&Plot' page of the configuration settings. Configuration settings may be accessed by pressing SHIFT CONF (F2). Refer to "6 Configuring" configurations.

Press 'PAGE (F6)' to move to the first page.

## 2.6

### Step 6) Using Offsets

#### Overview

It is often the case that it is necessary to set out points with a fixed plan offset and fixed height offset from a known reference line (centre line or rail). In RoadRunner Rail, these offsets may be entered manually or stored as part of the rail job and recalled whenever they are required.

Offsets are applied in the same way, irrespective of how the rail design has been entered and whether the offsets are manually entered or whether library offsets are used. The sign of the offsets conforms to the offset sign convention described in "8.5 Working with Offsets".

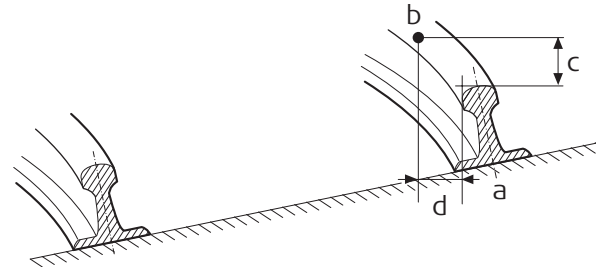

Rail12\_13

- a) Reference line (right rail)
- b) Point to stake
- c) Stake Ht. Offset
- d) Stake Offset

## Using offsets: enter manual offsets

| Rail Configuration |                   |
|--------------------|-------------------|
| General            | Rail              |
| SuperElev_Base:    | 1.500 m           |
| Nominal Gauge:     | 1.435 m           |
| Calc Chainage:     | Indirect Chain... |
| Offsets:           | From Library      |
| Use Cant:          | Manual            |
| CL Height:         | CL Geometry       |

|  |  |  |  |     |
|--|--|--|--|-----|
|  |  |  |  | Q2a |
|--|--|--|--|-----|

| Check Track    |             |
|----------------|-------------|
| General        | Info        |
| Point ID:      | 100         |
| Reflector Ht:  | 1.250 m     |
| Select Rail:   | Centre Line |
| Check Offset:  | 0.000 m     |
| Check Ht Diff: | 0.000 m     |
| Ht LowerRail:  | ----        |

|     |      |     |       |       |
|-----|------|-----|-------|-------|
|     |      |     |       | Q2A   |
| ALL | DIST | REC | <PAGE | PAGE> |

1 When the field "Offsets=Manual" is set in the configuration settings, then manual offsets may be entered using the 'Check Offset' field and the 'Check Ht. Diff' field. Refer to "6.3 Configuration Settings for the Program - Rail Config" for details on configuration settings.

## 2 Check Offset

The Check Offset is a horizontal offset applied to the position of the reference line as defined by the design data or to the position calculated using manually entered data using the nominal gauge.

### Check Ht Diff

The Check Ht Diff is a vertical offset applied to the height of the reference line as defined by the design data or to the position calculated using manually entered data using the superelevation and superelevation base.

## Using offsets: recall library offsets

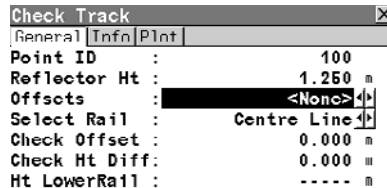
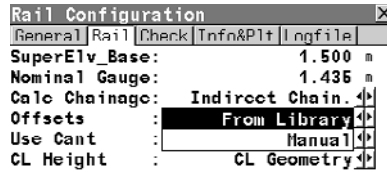

- 1 When the field "Offsets=From Library" is set in the configuration settings, the offsets that have been stored may be used. Refer to "6.3 Configuration Settings for the Program - Rail Config" for details on configuration settings.

## 2 Offsets

The point ID of the stored stake offsets. To select a different stored offset or to create a new point, highlight the current point ID in the 'Offsets' field and open the choicelist. Refer to "Defining the offsets" for details.

### Select Rail

Defines to which reference line the offset has been defined, three options are available:

Centre Line:

The horizontal alignment.

Left Rail:

The left rail as defined in the design data.

Right Rail:

The right rail as defined in the design data.

## Defining the offsets

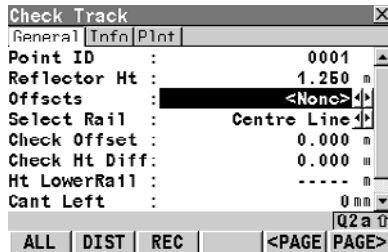

The screenshot shows a dialog box titled 'Check Track' with a close button (X) in the top right corner. The dialog has three tabs: 'General', 'Info', and 'Point', with 'General' selected. The following fields are visible:

- Point ID : 0004
- Reflector Ht : 1.250 m
- Offsets : <None>
- Select Rail : Centre Line
- Check Offset : 0.000 m
- Check Ht Diff : 0.000 m
- Ht LowerRail : ---- m
- Cant Left : 0 mm

At the bottom of the dialog, there is a status bar with the text 'Q2 a 0' and a set of navigation buttons: 'ALL', 'DIST', 'REC', '<PAGE', and 'PAGE>'.

### Check Offset

The Check Offset is a horizontal offset applied to the position of the reference line as defined by the design data or to the position calculated using manually entered data using the nominal gauge.

### Check Ht Diff

The Check Ht Diff is a vertical offset applied to the height of the reference line as defined by the design data or to the position calculated using manually entered data using the superelevation and superelevation base.

- 1 To select a different stored offset or to create a new point, highlight the current point ID in the 'Offsets' field and open the choicelist.



| Rail Job: Rail_uhne Höhe u-Schien X |         |             |
|-------------------------------------|---------|-------------|
| Point ID                            | Offset  | Height Diff |
| <None>                              | ----    | ----        |
| 0001                                | 1.500 m | 2.500 m     |

|      |     |      |     |      |        |
|------|-----|------|-----|------|--------|
| CONT | ADD | EDIT | DEL | MORE | Q2 a ↑ |
|------|-----|------|-----|------|--------|

- 2 This screen allows offsets relative to a reference line to be defined and stored in the rail job. These points may be recalled at any time.

**CONT (F1)**

To select the point and to continue.

**ADD (F2)**

To enter a new point.

**EDIT (F3)**

To edit an existing point.

**DEL (F4)**

To delete an existing point.

**MORE (F5)**

To display additional point information.

Press 'ADD (F2)' to enter a new point.

| Rail Job: Rail_uhne Höhe u-Schien X |     |
|-------------------------------------|-----|
| Offsets                             | Map |

Point ID : 0001  
 Ref. Rail : Centre Line ↓  
 Offset : 1.500 m  
 Height Diff. : 2.500 m

|      |  |  |  |  |        |
|------|--|--|--|--|--------|
| CONT |  |  |  |  | Q2 a ↑ |
|      |  |  |  |  | PAGE   |

- 3 This screen allows the values of the check offsets to be entered/edited. In addition to the horizontal and vertical offsets, a point ID may be entered for each point.

**CONT (F1)**

To record the point and to continue.

## 2.7

## Step 7) Using the Extras Menu

### Overview

Additional functions for checking the track may be accessed through the Extras menu. This functionality is additional to those already existing functions which are available via the function check keys. The Extras menu is accessed from every check screen.

### Accessing Extras Menu

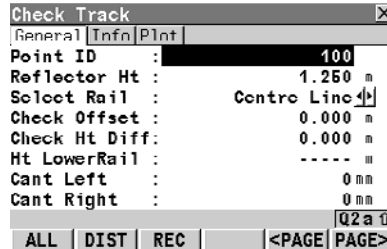

1. Press 'SHIFT EXTRA (F5)' to access the Extras menu.



2. **Manual/DTH Height**

Allows an absolute design height to be entered manually for checking the track.

#### **Reset heights to Design**

The manual height is active until it is turned off with 'Reset Height to Design' in the Extras menu.

#### **2nd point of Cant**

To determine the actual cant of two rails.

**Extras:  
Manual/DTM Height**

Manual/DTM Height ✕  
Height from : **Manual Height** ↕  
Height : 621.566 m

|      |  |  |  |  |     |
|------|--|--|--|--|-----|
|      |  |  |  |  | a ↑ |
| CONT |  |  |  |  |     |

With 'Height from=Manual Height', the heights can be entered manually.

Manual/DTM Height ✕  
Height from : **DTM Layer** ↕  
Height : 621.566 m  
DTM Layer : **Existing** ↕

|      |  |  |  |  |     |
|------|--|--|--|--|-----|
|      |  |  |  |  | a ↑ |
| CONT |  |  |  |  |     |

With 'Height from=DTM Layer', the heights can be obtained from the layers of the DTM Job. This option is only active when a DTM Job has been assigned to the project. Refer to "4 Managing your Projects and Jobs" for details on assigning jobs to projects.

**Extras:**  
**Second point of Cant**

| 2nd Point of Cant |              |      |
|-------------------|--------------|------|
| General           | Tnfn         | PInt |
| Rail Task :       | <Rail>       |      |
| Rail Name :       | Centre Line  |      |
| Chainage :        | 52016.0402 m |      |
| Ref Offset :      | 5.6203 m     |      |
| Ref Ht Diff :     | -0.9267 m    |      |
| Ht Diff LwrR1 :   | -0.9267 m    |      |
| Ht LowerRail :    | 619.0500 m   |      |
| Current Cant :    | 0.2001 m     |      |

Q2 a

ALL DIST REC <PAGE PAGE>

In order to calculate the current cant, it is necessary to measure two points, one on each rail. A mechanical device may be used to measure these points if required.

Additionally, the current cant can be calculated by firstly measuring any two points (example, the track centre line and lower rail) and secondly by using the superelevation base. The calculation is dependent upon the superelevation base.

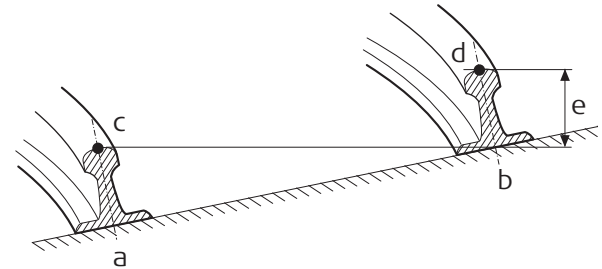

- Rail12\_15
- a) left rail
  - b) right rail
  - c) first point
  - d) second point of cant
  - e) current cant

**Measuring the first point**

The first point may be measured directly from the Check Track panel.

**Measuring the second point**

The second point should be measured after accessing the 2nd Point of Cant function in the Extras menu. Once the second point has been measured, the value Current Cant will be displayed on the 'Info' page.

---

# 3 Setting out a Track with Rail Stake-Out

## 3.1 Step 1) Positioning the Receiver (for GPS only)

### Positioning the sensor

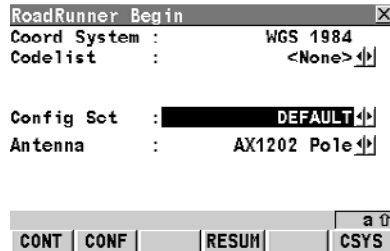

Once the task has been defined and selected, the receiver can be set.

Select the necessary coordinate system, codelist, configuration set and antenna for the survey. All stake-out methods and check methods share this common screen.

It is possible to skip this screen. Refer to "6 Configuring" for configurations.

#### **CONT (F1)**

To continue to the next screen.

#### **CONF (F2)**

To access the configuration settings.

Refer to "6 Configuring" for configurations.

#### **RESUM (F4)**

To resume the last task running of the highlighted project. The project to which the task belongs to is selected automatically.

#### **CSYS (F6)**

To change the current coordinate system.

Press 'CONT (F1)' to continue to the next screen.

## 3.2

### Step 2) Positioning the Instrument (for TPS only)

#### Positioning the sensor

RoadRunner Begin [X]

Coord System : CS1

CodeList : <None>

Config Set : TCRP

Reflector : Leica Circ Prism

Add. Constant: 0.0 mm

a

CONT CONF SETUP RESUM CSYS

Once the task has been defined and selected, the instrument can be positioned and oriented. This screen allows the instrument position to be established.

Select the necessary coordinate system, codelist, configuration set and reflector for the survey. All stake-out methods and check methods share this common screen.

It is possible to skip this screen. Refer to "6 Configuring" for configurations.

#### **CONT (F1)**

To continue to the next screen.

#### **CONF (F2)**

To access the configuration settings.

Refer to "6 Configuring" for configurations.

#### **SETUP (F3)**

To allow the station coordinates and orientation to be entered or calculated.

**RESUM (F4)**

To resume the last task running of the highlighted project. The project to which the task belongs to is selected automatically.

**CSYS (F6)**

To change the current coordinate system.

Press 'CONT (F1)' to continue to the next screen.

---



### 3.3

## Step 3) Selecting Rail Stake-Out

### Selecting Stake-Out

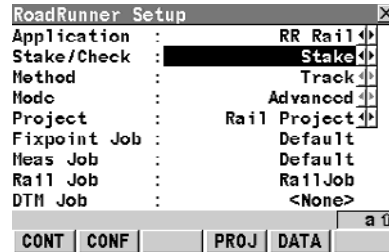

1. Refer to "1 Getting Started with RoadRunner Rail" for details on starting setting out surveys.

2. Select 'Stake' and 'Track'.

Press 'CONF (F2)' to access configuration settings. Refer to "6 Configuring" for configurations.

Press 'CONT (F1)' to continue to the next screen.

## 3.4

### Creating/Selecting a task

## Step 4) Creating/Selecting a Task

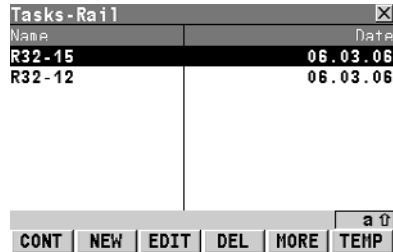

The screenshot shows a window titled "Tasks - Rail" with a close button (X) in the top right corner. The window contains a table with two columns: "Name" and "Date". The first row is highlighted in black and contains "R32-15" and "06.03.06". The second row contains "R32-12" and "06.03.06". Below the table is a menu bar with buttons for "CONT", "NEW", "EDIT", "DEL", "MORE", and "TEMP". A cursor is positioned over the "TEMP" button, and a small "a" icon is visible next to it.

| Name   | Date     |
|--------|----------|
| R32-15 | 06.03.06 |
| R32-12 | 06.03.06 |

CONT NEW EDIT DEL MORE TEMP

In order to stake a track, a task needs to be created or selected. The task defines which track is to be staked and also defines any shifts that are to be used during the setting out survey.

This screen lists already defined tasks.

Refer to "5.3 Working with the Tasks" for details on creating/selecting tasks.

#### **CONT (F1)**

To continue to the next screen.

#### **NEW (F2)**

To create a new task.

#### **EDIT (F3)**

To edit the selected task.

#### **DEL (F4)**

To delete the selected task.

#### **MORE (F5)**

To toggle between date and time info.

#### **TEMP (F6)**

To create a temporary task. This task is identical to any other task but is not stored for later use.

Press 'CONT (F1)' to continue to the next screen.

## 3.5

### Step 5) Setting Out the Track

#### Overview

| Stake Track     |              |
|-----------------|--------------|
| General         | Stake        |
| Point ID :      | 100001       |
| Reflector Ht :  | 1.1500 m     |
| Def Chainage :  | 52000.0000 m |
| Ch Increment :  | 0.0000 m     |
| Select Rail :   | Centre Line  |
| Stake Offset :  | 0.0000 m     |
| Stake Ht Diff : | 0.0000 m     |

Q2 a ↑

|     |      |     |     |       |       |
|-----|------|-----|-----|-------|-------|
| ALL | DIST | REC | CH+ | <PAGE | PAGE> |
|-----|------|-----|-----|-------|-------|

It is possible to set out points using a rail job with and without a stored rail design.

When the position of the rails is not stored in the rail job, it is possible to set-out:

- The horizontal and vertical alignments
- Points with a known horizontal and vertical offset from the horizontal and vertical alignments
- The rails of the track by entering the track superelevation, superelevation base and nominal gauge
- Points with know horizontal and vertical offsets from the manually defined rails.

When the position of the rails is stored in the rail job, it is possible to set-out:

- The horizontal and vertical alignments
- Points with a known horizontal and vertical offset from the horizontal and vertical alignments
- The rails of the track
- Points with know horizontal and vertical offsets from the defined rails.

## Defining the point to set out

| Stake Track    |              |
|----------------|--------------|
| General        | Stake        |
| Point ID :     | 101          |
| Reflector Ht : | 0.1000 m     |
| Def Chainage : | 52000.0000 m |
| Ch Increment : | 0.0000 m     |
| Select Rail :  | Centre Line  |
| Stake Offset : | 0.0000 m     |
| Stake Ht Diff: | 0.0000 m     |

|     |      |     |     |       |     |       |
|-----|------|-----|-----|-------|-----|-------|
| ALL | DIST | REC | CH+ | <PAGE | Q2a | PAGE> |
|-----|------|-----|-----|-------|-----|-------|

When setting out the track, a number of fields that may be entered in the 'General' page are identical whether or not the rail design is stored in the rail job.

### Point ID

The point ID of the point that will be set out.

### GPS Antenna Ht

The antenna height.

### TPS Reflector Ht

The reflector height.

### Def Chainage

The defined chainage of the point to be set out. In the case of multiple tracks that have a defined chainage centre line, the chainage to be set out always refers to the chainage of the chainage centre line and not to the chainage of the track centre line.

### Ch Increment

If a point is to be staked at more than one chainage, a chainage increment may be defined. Use of the remaining parameters on the General panel changes slightly depending on whether a vertical alignment is available and whether the rail data has been stored within the job.

## Working with a horizontal alignment

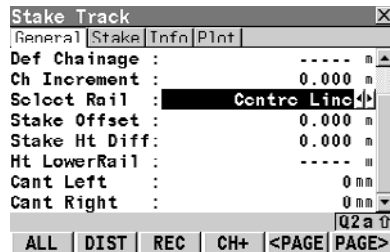

### Stake Offset

The Stake Offset is a horizontal offset applied to the position of the reference line as defined by the design data or to the position calculated using manually entered data using the nominal gauge.

### Stake Ht Diff

The Stake Ht Diff is a vertical offset applied to the height of the reference line as defined by the design data or to the position calculated using manually entered data using the superelevation and superelevation base.

If the only defined data available is the horizontal alignment, the position and height of the rail data may be defined as follows.

### Select Rail

Defines which reference line should be staked.

Three options are available:

Centre Line:

The horizontal alignment.

Left Rail:

The position of the left rail is calculated using the nominal gauge entered in the program configuration. The height of the rail is calculated using the value of the Ht LowerRail parameter and the left / right superelevation.

Right Rail:

The position of the right rail is calculated using the nominal gauge entered in the program configuration. The height of the rail is calculated using the value of the Ht LowerRail parameter and the left / right superelevation.

**Ht LowerRail**

Defines the absolute height of the lowest rail at the defined chainage.

**Cant Left**

Defines the superelevation at the left rail. If the track is rotated around the left rail, the superelevation would be zero.

**Cant Right**

Defines the superelevation at the right rail. If the track is rotated around the right rail, the superelevation would be zero. The total superelevation (left + right) is applied across the distance defined as the superelevation base in the configuration.

---

## Working with a horizontal and a vertical alignment

| Stake Track     |            |     |     |       |       |
|-----------------|------------|-----|-----|-------|-------|
| General         | Stake      |     |     |       |       |
| Reflector Ht :  | 1.250 m    |     |     |       |       |
| Def Chainage :  | ----- m    |     |     |       |       |
| Ch Increment :  | 0.000 m    |     |     |       |       |
| Select Rail :   | Right Rail |     |     |       |       |
| Stake Offset :  | 0.000 m    |     |     |       |       |
| Stake Ht Diff : | 0.000 m    |     |     |       |       |
| Cant Left :     | 0 mm       |     |     |       |       |
| Cant Right :    | 0 mm       |     |     |       |       |
| Q2a             |            |     |     |       |       |
| ALL             | DIST       | REC | CH+ | <PAGE | PAGE> |

If the available defined data is the horizontal and vertical alignment, the position and height of the rail data may be defined as follows.

### Select Rail

Defines which reference line should be staked.

Three options are available:

Centre Line:

The horizontal alignment.

Left Rail:

The position of the left rail is calculated using the nominal gauge entered in the program configuration. The height of the rail is calculated using the height of the vertical alignment at the defined chainage and the left / right superelevation.

Right Rail:

The position of the right rail is calculated using the nominal gauge entered in the program configuration. The height of the rail is calculated using the height of the vertical alignment at the defined chainage and the left / right superelevation.

## Working with a horizontal and a vertical alignment and a stored rail design

| Stake Track     |              |
|-----------------|--------------|
| General         | Stake        |
| Point ID :      | 100          |
| Reflector Ht :  | 1.250 m      |
| Def Chainage :  | ----- m      |
| Ch Increment :  | 0.000 m      |
| Select Rail :   | Right Rail ↓ |
| Stake Offset :  | 0.000 m      |
| Stake Ht Diff : | 0.000 m      |

|     |      |     |     |       |        |       |
|-----|------|-----|-----|-------|--------|-------|
| ALL | DIST | REC | CH+ | <PAGE | Q2 a ↑ | PAGE> |
|-----|------|-----|-----|-------|--------|-------|

### Cant Left

Defines the superelevation at the left rail. If the track is rotated around the left rail, the vertical alignment would coincide with the left rail and the superelevation would thus be zero.

### Cant Right

Defines the superelevation at the right rail. If the track is rotated around the right rail, the vertical alignment would coincide with the right rail and the superelevation would thus be zero. The total superelevation (left + right) is applied across the distance defined as the superelevation base in the configuration.

If the position and height of the rail data is available in the rail job, the setting out data may be defined as follows.

### Select Rail:

Defines which reference line should be staked. Three options are available:

Centre Line:

The horizontal alignment.

Left Rail:

The left rail as defined in the design data.

Right Rail:

The right rail as defined in the design data.



## 3.6

## Step 6) Understanding the Stake Pages

### The General page

| Stake Track     |              |
|-----------------|--------------|
| General         | Stake        |
| Point ID :      | 101          |
| Reflector Ht :  | 0.1000 m     |
| Def Chainage :  | 52000.0000 m |
| Ch Increment :  | 0.0000 m     |
| Select Rail :   | Centre Line  |
| Stake Offset :  | 0.0000 m     |
| Stake Ht Diff : | 0.0000 m     |

Q2 a ↑

ALL DIST REC CH+ <PAGE> PAGE>

[TPS] Once the point to set out has been defined, the sensor may be positioned manually and the ALL (F1), DIST (F2) and REC (F3) keys may be used to measure a point. Alternatively, press 'POSIT SHIFT (F5)' key to move the instrument to point at the stake out position. The differences between the measured point and the defined point may be viewed in the 'Stake', 'Info' and 'Plot' pages.

Press 'CONT (F1)' to continue to the next screen.

### The Stake page

| Stake Track |              |
|-------------|--------------|
| General     | Stake        |
| Ch :        | 52000.2407 m |
| CL 0 :      | -0.1965 m    |
| ΔCh : ↓     | -0.2407 m    |
| ΔOff : →    | 0.1965 m     |
| ΔHt : ↓     | -0.0046 m    |
| NrTP :      | 172.2586 m   |

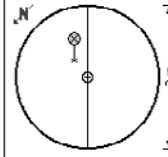

Q2 a ↑

ALL DIST REC CH+ <PAGE> PAGE>

During setting out the differences between the measured point and the defined point may be seen in the 'Stake' page.

The layout of this page may appear with or without graphics depending upon the values set in the configuration settings.

Refer to "6 Configuring" for configurations.

The position of the point to stake will be reached when all difference values are close to zero.

Press 'CONT (F1)' to continue to the next screen.

## The Info page

| Parameter     | Value       | Unit |
|---------------|-------------|------|
| Rail Task     | <Rail>      |      |
| Rail Name     | Centre Line |      |
| Chainage      | 52000.2407  | m    |
| Ref Offset    | -0.1965     | m    |
| Ref Ht Diff   | 0.0046      | m    |
| Ht Diff LwrR1 | 0.0046      | m    |
| Ht LowerRail  | 519.0080    | m    |
| Cur Des Cant  | 0.5000      | m    |

The 'Info' page displays a series of values related to the setting out of the design point as required by the user.

The fields viewed in the 'Info' page may be configured by the user in the 'Info&Plot' page of the configuration settings. Configuration settings may be accessed by pressing SHIFT CONF (F2). Refer to "6 Configuring" for configurations.

Press 'PAGE (F6)' to move to the next page.

## The Plot page

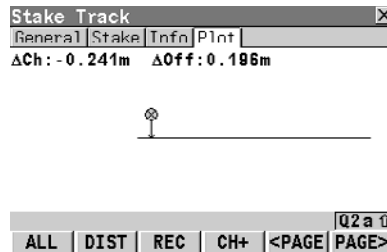

The 'Plot' page displays a plot of the measured point with respect to the track design.

The actual graphical representation shown in the 'Plot' page may be configured by the user in the 'Info&Plot' page of the configuration settings. Configuration settings may be accessed by pressing SHIFT CONF (F2). Refer to "6 Configuring" configurations.

Press 'PAGE (F6)' to move to the first page.

## 3.7

### Step 7) Using Offsets

#### Overview

It is often the case that it is necessary to set out points with a fixed plan offset and fixed height offset from a known reference line (centre line or rail). In RoadRunner Rail, these offsets may be entered manually or stored as part of the rail job and recalled whenever they are required.

Offsets are applied in the same way, irrespective of how the rail design has been entered and whether the offsets are manually entered or whether library offsets are used. The sign of the offsets conforms to the offset sign convention described in "8.5 Working with Offsets".

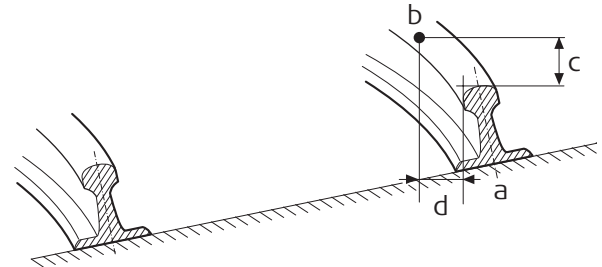

Rail12\_13

- a) Reference line (right rail)
- b) Point to stake
- c) Stake Ht. Offset
- d) Stake Offset

## Using offsets: enter manual offsets

| Rail Configuration |                   |
|--------------------|-------------------|
| General            | Rail              |
| SuperElev_Base:    | 1.500 m           |
| Nominal Gauge:     | 1.435 m           |
| Calc Chainage:     | Indirect Chain... |
| Offsets:           | From Library      |
| Use Cant:          | Manual            |
| CL Height:         | CL Geometry       |

|      |  |  |  |  |
|------|--|--|--|--|
| Q2 a |  |  |  |  |
|      |  |  |  |  |

| Stake Track    |           |
|----------------|-----------|
| General        | Stake     |
| Point ID:      | 0001      |
| Reflector Ht:  | 1.250 m   |
| Dcf Chainage:  | ----- m   |
| Ch Increment:  | 0.000 m   |
| Select Rail:   | Left Rail |
| Stake Offset:  | 0.000 m   |
| Stake Ht Diff: | 0.000 m   |
| Ht LowerRail:  | ----- m   |

|      |      |     |     |       |       |
|------|------|-----|-----|-------|-------|
| Q2 a |      |     |     |       |       |
| ALL  | DIST | REC | CH+ | <PAGE | PAGE> |

1. When the field "Offsets=Manual" is set in the configuration settings, then manual offsets may be entered using the 'Stake Offset' field and the 'Stake Ht. Diff' field. Refer to "6.3 Configuration Settings for the Program - Rail Config" for details on configuration settings.

## 2. Stake Offset

The Stake Offset is a horizontal offset applied to the position of the reference line as defined by the design data or to the position calculated using manually entered data using the nominal gauge.

## Stake Ht Diff

The Stake Ht Diff is a vertical offset applied to the height of the reference line as defined by the design data or to the position calculated using manually entered data using the superelevation and superelevation base.

## Using offsets: recall library offsets

| Rail Configuration |                |
|--------------------|----------------|
| General            | Rail           |
| SuperElev_Base:    | 1.500 m        |
| Nominal Gauge:     | 1.435 m        |
| Calc Chainage:     | Indirect Chain |
| Offsets:           | From Library   |
| Use Cant:          | Manual         |
| CL Height:         | CL Geometry    |

|     |  |  |  |  |
|-----|--|--|--|--|
| Q2a |  |  |  |  |
|     |  |  |  |  |

| Stake Track    |           |
|----------------|-----------|
| General        | Stake     |
| Point ID:      | 0001      |
| Reflector Ht:  | 1.250 m   |
| Def Chainage:  | ----- m   |
| Ch Increment:  | 0.000 m   |
| Offsets:       | <None>    |
| Select Rail:   | Left Rail |
| Stake Offset:  | 0.000 m   |
| Stake Ht Diff: | 0.000 m   |

|     |      |     |     |       |       |
|-----|------|-----|-----|-------|-------|
| Q2a |      |     |     |       |       |
| ALL | DIST | REC | CH+ | <PAGE | PAGE> |

1. When the field "Offsets=From Library" is set in the configuration settings, the offsets that have been stored may be used. Refer to "6.3 Configuration Settings for the Program - Rail Config" for details on configuration settings.

## 2. Offsets

The point ID of the stored stake offsets. To select a different stored offset or to create a new point, highlight the current point ID in the 'Offsets' field and open the choicelist. Refer to "Defining the offsets" for details.

### Select Rail

Defines to which reference line the offset has been defined, three options are available:

Centre Line:

The horizontal alignment.

Left Rail:

The left rail as defined in the design data.

Right Rail:

The right rail as defined in the design data.

## Defining the offsets

| Stake Track    |             |     |     |       |       |
|----------------|-------------|-----|-----|-------|-------|
| General        | Stake       |     |     |       |       |
| Point ID :     | 100         |     |     |       |       |
| Reflector Ht : | 1.250 m     |     |     |       |       |
| Def Chainage : | ----- m     |     |     |       |       |
| Ch Increment : | 0.000 m     |     |     |       |       |
| Offsets :      | <None>      |     |     |       |       |
| Select Rail :  | Centre Line |     |     |       |       |
| Stake Offset : | 0.000 m     |     |     |       |       |
| Stake Ht Diff: | 0.000 m     |     |     |       |       |
| Q2 a           |             |     |     |       |       |
| ALL            | DIST        | REC | CH+ | <PAGE | PAGE> |

### Stake Offset

The Stake Offset is a horizontal offset applied to the position of the reference line as defined by the design data or to the position calculated using manually entered data using the nominal gauge.

### Stake Ht Diff

The Stake Ht Diff is a vertical offset applied to the height of the reference line as defined by the design data or to the position calculated using manually entered data using the superelevation and superelevation base.

1. To select a different stored offset or to create a new point, highlight the current point ID in the 'Offsets' field and open the choicelist.

| Rail Job: Rail_uhne Höhe u-Schien X |         |             |
|-------------------------------------|---------|-------------|
| Point ID                            | Offset  | Height Diff |
| <None>                              | ----    | ----        |
| 0001                                | 1.500 m | 2.500 m     |

|      |     |      |     |      |        |
|------|-----|------|-----|------|--------|
| CONT | ADD | EDIT | DEL | MORE | Q2 a ↑ |
|------|-----|------|-----|------|--------|

2. This screen allows offsets relative to a reference line to be defined and stored in the rail job. These points may be recalled at any time.

**CONT (F1)**

To select the point and to continue.

**ADD (F2)**

To enter a new point.

**EDIT (F3)**

To edit an existing point.

**DEL (F4)**

To delete an existing point.

**MORE (F5)**

To display additional point information.

Press 'ADD (F2)' to enter a new point.

| Rail Job: Rail_uhne Höhe u-Schien X |               |
|-------------------------------------|---------------|
| Offsets                             | Map           |
| Point ID :                          | 0001          |
| Ref. Rail :                         | Centre Line ↓ |
| Offset :                            | 1.500 m       |
| Height Diff. :                      | 2.500 m       |

|      |  |  |  |  |        |
|------|--|--|--|--|--------|
| CONT |  |  |  |  | Q2 a ↑ |
|      |  |  |  |  | PAGE   |

3. This screen allows the values of the stake offsets to be entered/edited. In addition to the horizontal and vertical offsets, a point ID may be entered for each point.

**CONT (F1)**

To record the point and to continue.

## 3.8

## Step 8) Using the Extras Menu

### Overview

Additional functions for setting out the track may be accessed through the Extras menu. This functionality is additional to those already existing functions which are available via the function keys. The Extras menu is accessed from every stake screen.

### Accessing Extras Menu

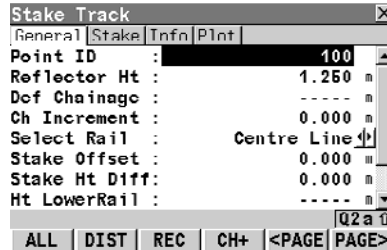

1. Press 'SHIFT EXTRA (F5)' to access the Extras menu.

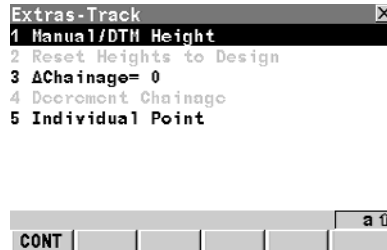

2. **Manual/DTH Height**

Allows an absolute design height to be entered manually for staking the track.

#### **Reset heights to Design**

The manual height is active until it is turned off with Reset Height to Design in the Extras menu.

#### **ΔChainage=0**

This sets the defined chainage to the current measured chainage.



**Extras:**  
**Manual/DTM Height**

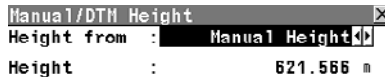

Manual/DTM Height [X]  
Height from : Manual Height [v]  
Height : 621.566 m



CONT [ ] [ ] [ ] [ ] [ ] [ ] a u

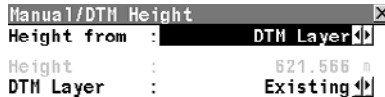

Manual/DTM Height [X]  
Height from : DTM Layer [v]  
Height : 621.566 m  
DTM Layer : Existing [v]



CONT [ ] [ ] [ ] [ ] [ ] [ ] a u

**Decrement Chainage**

This decreases the defined chainage used for the stakeout by the amount defined in the increment chainage parameter.

**Individual Point D**

This allows a 2D or 3D point for staking out to be selected from the fixed point job.

With 'Height from=Manual Height', the heights can be entered manually.

With 'Height from=DTM Layer', the heights can be obtained from the layers of the DTM Job. This option is only active when a DTM Job has been assigned to the project. Refer to "4 Managing your Projects and Jobs" for details on assigning jobs to projects.

# 4

## 4.1

### Overview

# Managing your Projects and Jobs

## Overview

Working on a railway construction site implies working with various data such as:

- Control points
- Horizontal and vertical alignments
- Measurement data
- Rail design
- Digital Terrain Models (DTM)

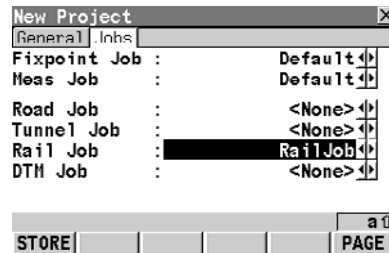

To avoid having to select individual data sets each time the program is used, data can be grouped into projects. This makes the selection much easier and reduces the risk of selecting a wrong data set.

The job options are:

1. fixpoint job
2. measurement job
3. tunnel job
4. rail job
5. digital terrain Job (DTM)

| Screen | Description |
|--------|-------------|
|--------|-------------|

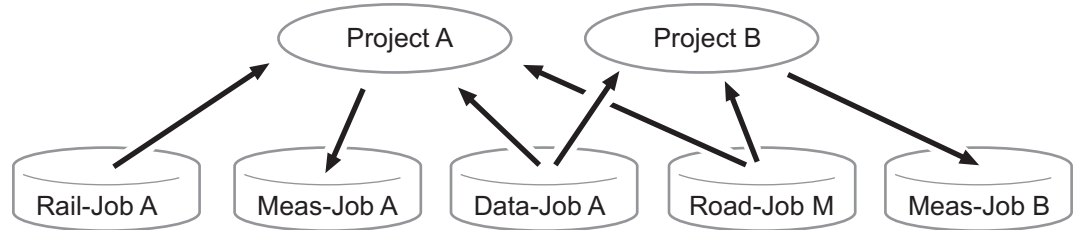

Rail12\_12

**Project**



A project consists of different kinds of jobs that are grouped together to form a project. By selecting a project all referenced jobs are selected automatically as well.

A project can reference:

- one data job
- one measurement job
- one road job
- one rail job
- one DTM job.

Since jobs are only referenced by a project, they may be used in more than one RoadRunner project, as well as in other programs. For example the same collection of control points may be used in two different projects.

| Screen                     | Description  |
|----------------------------|--|
|                            | <p>Project A and Project B reference the same data job (Data-Job A) and road job (Road-Job M), however, their results are stored into different measurement jobs (Meas-Job A; Meas-Job B). In addition, Project A references the rail design data through a Rail Job (Rail Job A).</p>   |
| <p><b>Fixpoint Job</b></p> | <p>The Data Job holds all control point information needed in the field. For example, control points, points with known coordinates used for a TPS set-up.</p>   |
| <p><b>Meas Job</b></p>     | <p>The measurement job is where information generated in the field is recorded. All measurements, points and other values stored in the field are added to this job.</p>   |
| <p><b>Road Job</b></p>     | <p>All design information for road data, either typed in manually or exported from a design package is stored in the road job. Data stored in this job could include, for example, information related to the construction of cuttings and embankments. Like the data job, it is a source of information. Refer to the RoadRunner Technical Reference Manual, chapter 6 "Road Job" for details on road jobs.</p> |

| Screen  | Description   |
|---|---|
| <b>Tunnel Job</b>   | Contains information relating to the design of a tunnel. The centre line of the tunnel and the tunnel design profiles are stored in the tunnel job. As with a road job, the tunnel job is a read-only source of information. Refer to the RoadRunner Tunnel Technical Reference Manual for details. |
| <b>Rail Job</b>   | Contains information relating to the design of the tracks. The centre line(s) of the track and the rails are stored in the rail job. As with a road job, the rail job is a read-only source of information.<br><br>Refer to "5 Managing the Rail Job"for details.                                   |
| <b>Digital Terrain Model Job</b>  | Holds DTM (Digital Terrain Model) data or TIN (Triangular Irregular Network) data. Like a data job or road job, the DTM job is a source of information. Refer to the RoadRunner Technical Reference Manual for details.   |
|  | The same job can be used as a data and measurement job.   |
|  | Since Road jobs, Tunnel jobs, Rail jobs and DTM jobs are read only, they cannot be selected as a data or a measurement job. When selecting a job, a filter is applied to show only the valid jobs in the selection list.  |

## 4.2

### Browsing from a list of existing projects

## Selecting a Project by Browsing a List of Projects

| Projects (CF Card) |          |
|--------------------|----------|
| Name               | Date     |
| Soccer             | 16.10.06 |
| ELLIS              | 30.10.06 |
| SAMPLE             | 17.10.06 |
| RR_Exercise_3      | 31.03.04 |
| RR_EXERCISE_2      | 31.03.04 |
| RR_Exercise 5      | 30.03.04 |
| Default Project    | 30.03.04 |

CONT NEW EDIT DEL MORE INTL

A list of all available projects in the internal memory or on the CompactFlash card are available via the project browser.

### CONT (F1)

To select the highlighted project and continue.

### NEW (F2)

To create a new project.

### EDIT (F3)

To edit the highlighted project. This project also becomes the active project.

### DEL (F4)

To delete the highlighted project.

### MORE (F5)

Toggle between Date and Time info

### CFCRD (F6) or INTL (F6)

To switch between the CompactFlash card and internal memory as the active device.

## 4.3

### Selecting a Project by Resuming the Last Task

#### Resuming the last task

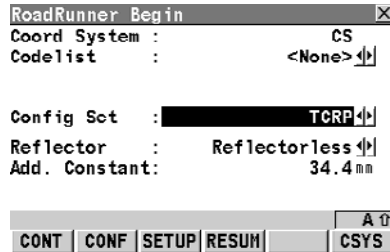

RoadRunner Begin [X]

Coord System : CS

CodeList : <None> [Left][Right]

Config Sct : TCRF [Down][Up]

Reflector : Reflectorless [Left][Right]

Add. Constant: 34.4 mm

[CONT] [CONF] [SETUP] [RESUM] [A ↑] [CSYS]

RoadRunner retains the last active task used on any project. When the program is resumed, the last active task may be accessed again using the RESUM (F4) key. This avoids the selection of project and task to be staked out or checked every time the program is started.

#### RESUM (F4)

To resume the last task running of the highlighted project. The project to which the task belongs to is selected automatically.

## 4.4

## Creating a New Project

### Creating a project

| Projects (CF Card) |          |
|--------------------|----------|
| Name               | Date     |
| Soccer             | 16.10.06 |
| ELLIS              | 30.10.06 |
| SAMPLE             | 17.10.06 |
| RR_Exercise_3      | 31.03.04 |
| RR_EXERCISE_2      | 31.03.04 |
| RR_Exercise 5      | 30.03.04 |
| Default Project    | 30.03.04 |

A ↑

CONT NEW EDIT DEL MORE INTL

1. Press 'NEW (F2)' to move to the next screen.

| New Project   |           |
|---------------|-----------|
| General       | Inhs      |
| Name :        | -----     |
| Description : | -----     |
| Creator :     | -----     |
| Device :      | CF Card ↓ |

Q2 a ↑

STORE PAGE

2. **New Project, General page**  
Enter a 'Name' (this field is compulsory).  
Enter a 'Description'.  
Enter a 'Creator'.  
Enter a 'Device' for the project.

Press 'PAGE (F6)' to move to the next page.

| New Project    |            |
|----------------|------------|
| General        | Inhs       |
| Fixpoint Job : | Default ↓  |
| Meas Job :     | Default ↓  |
| Road Job :     | <None> ↓   |
| Tunnel Job :   | <None> ↓   |
| Rail Job :     | Rail Job ↓ |
| DTM Job :      | <None> ↓   |

a ↑

STORE PAGE

3. **New Project, Jobs page**  
Select the 'Fixpoint Job'.  
Select the 'Meas Job'.  
Select the 'Rail Job'.  
Select the 'DTM Job'.  
It is possible to add or remove jobs at a later stage.

Press 'STORE (F1)' to accept the changes and select the newly created project as the new active project.



## 4.5

## Editing an Existing Project

### Editing a project

```
RoadRunner Setup
Application : RR Rail
Stake/Check : Stake
Method : Track
Mode : Advanced
Project : Rail Project
Fixpoint Job : Default
Meas Job : Default
Rail Job : RailJob
DTM Job : Soccer DTM

a ↑
CONT CONF PROJ DATA
```

1. Select the Project line and press **ENTER** to open the projects panel.

```
Projects (CF Card)
Name Date
Soccer 16.10.06
ELLIS 30.10.06
SAMPLE 17.10.06
RR_Exercise_3 31.03.04
RR_EXERCISE_2 31.03.04
RR_Exercise 5 30.03.04
Default Project 30.03.04

A ↑
CONT NEW EDIT DEL MORE INTL
```

2. Press 'EDIT (F3)' to move to the next screen.

```
Edit Project: Rail Project
General Inhs
Name : Rail Project
Description :
:
Creator :
Device : CF Card

a ↑
STORE PAGE
```

3. **Edit Project, General page**  
Enter a 'Name' (this field is compulsory).  
Enter a 'Description'.  
Enter a 'Creator'.  
Enter a 'Device' for the project.

Press 'PAGE (F6)' to move to the next page.

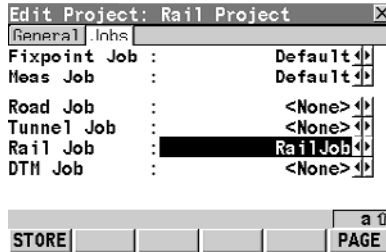

#### 4. Edit Project, Jobs page

Select the 'Fixpoint Job'.

Select the 'Meas Job'.

Select the 'Rail Job'.

Select the 'DTM Job'.

It is possible to add or remove jobs at a later stage.

Press 'STORE (F1)' to accept the changes and select the newly created project as the new active project.

## 4.6

## Deleting an Existing Project

### Deleting a project

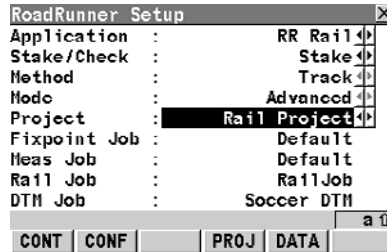

RoadRunner Setup

|                |              |
|----------------|--------------|
| Application :  | RR Rail      |
| Stake/Check :  | Stake        |
| Method :       | Track        |
| Mode :         | Advanced     |
| Project :      | Rail Project |
| Fixpoint Job : | Default      |
| Meas Job :     | Default      |
| Rail Job :     | RailJob      |
| DTM Job :      | Soccer DTM   |

CONT CONF PROJ DATA

1. Select the Project line and press **ENTER** to open the projects panel. Deleting a project will not delete the fixpoint job, measurement job, road job, tunnel job, rail job or DTM job that it references.

If two projects use the same control points by referencing the same fixpoint job, deleting one project will not delete the control points for the other project.

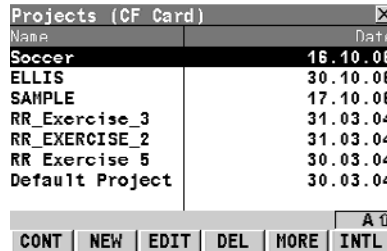

Projects (CF Card)

| Name            | Date     |
|-----------------|----------|
| Soccer          | 16.10.06 |
| ELLIS           | 30.10.06 |
| SAMPLE          | 17.10.06 |
| RR_Exercise_3   | 31.03.04 |
| RR_EXERCISE_2   | 31.03.04 |
| RR_Exercise 5   | 30.03.04 |
| Default Project | 30.03.04 |

CONT NEW EDIT DEL MORE INTL

2. Highlight the project to delete. Press 'DEL (F4)' to delete the project.

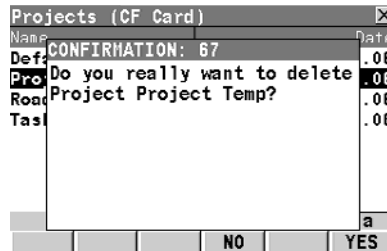

Projects (CF Card)

CONFIRMATION: 67

Do you really want to delete Project Project Temp?

| Name | Date |
|------|------|
| Def  | .06  |
| Pro  | .06  |
| Road | .06  |
| Tas  | .06  |

NO YES

3. Press 'YES (F6)' to confirm the deletion.

# 5

## 5.1

### Overview

# Managing the Rail Job

## Overview

---

Each rail job consists of two major parts:

**Part 1: Design data:**

Contains all the information about the rail design including the geometry of the centre line and the rail definition (superelevation).

**Part 2: Working tasks:**

Tasks define how the design elements of the track are staked out or checked in the field. Tasks also define any offsets that should be applied to the design data.

---

**Horizontal alignments  
and vertical alignments**

All rail jobs must consist of at least one horizontal alignment. Each horizontal alignment may be typed in manually using the System 1200 Alignment Toolkit program or converted from a rail design package using the 'Design To Field' component within the Leica Geo Office program.

Horizontal alignments may consist of straights, circular curves, clothoides, parabolic curves and blossom curves.

Vertical alignments may consist of straights, circular curves and parabolic curves.

If a design comprises of multiple tracks, one horizontal alignment may be defined as the chainage centre line from which all chainages will be calculated and additional horizontal and vertical alignments may be used to define each track.

---

## Rail definition

Rails may be defined by entering the design data manually in the field, by using the System1200 Alignment Toolkit program, by using the Rail Editor PC program or by converting data from a rail design package using the 'Design To Field' component within the LEICA Geo Office program.

Rails are stored as stringlines (continuous 2D or 3D lines) within the rail job.

---

## Tracks

Tracks are used to group related stringlines (centre line and rails) together.

In the case of a single track, the track centre line and the two rails are grouped together in one track.

In the case of multiple tracks where one chainage centre line is used for all tracks, each track consists of four stringlines: the track centre line, the chainage centre line and the left and right rails.

In the case of multiple tracks where chainage is calculated relative to the track centre line, each track is stored as a single track as described previously.

---

## 5.3

### Working with the Tasks

#### Creating a task

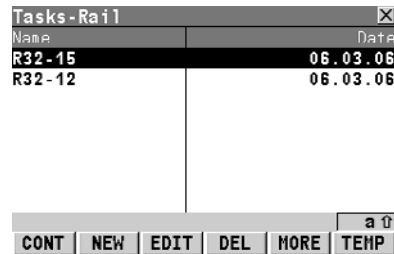

| Name   | Date     |
|--------|----------|
| R32-15 | 06.03.06 |
| R32-12 | 06.03.06 |

CONT NEW EDIT DEL MORE TEHP a ↑

1. When staking out or checking a track, it is often the case that it is not possible to finish a particular task in one go. Rail allows the possibility of storing the element to be staked out or checked together with all defined settings as a working task. Tasks are stored as a part of the project.

A task defines the offsets required for setting out and checking as well as the track to use and the chainage limits within which the task applies. When starting the Rail program, the seven last used tasks of the selected project are shown.

#### **CONT (F1)**

To continue to the next screen.

#### **NEW (F2)**

To create a new task.

#### **EDIT (F3)**

To edit the selected task.

#### **DEL (F4)**

To delete the selected task.

#### **MORE (F5)**

To toggle between date and time info.

## TEMP (F6)

To create a temporary task. This task is identical to any other task but is not stored for later use.

Press 'CONT (F1)' to continue to the next screen.

Selection Wizard-Start

Task Type : Rail

Task Name : RailNew

Shift Horizt1: None

Shift Verticl: None

NEXT Q2 a

2. The Selection Wizard-Start page defines the name of the task and whether shifts should be applied to the design data.

Shifts are applied temporarily to the design data for the defined task, the original design data is not modified when a shift is applied. Refer to "8.6 Working with Horizontal Shifts and Vertical Shifts" for details on shifts.

The same selection wizard is used for all tasks within the program.

Press 'NEXT (F1)' to move to the next page.

Selection Wizard-View

Track : Rail

Select View : Plan

Plot Chainage: 60820.499

NEXT DEFLT BACK Q2 a

3. The second page of the selection wizard defines the track or centre line to be used for the task.

Press 'NEXT (F1)' to move to the next page.





4. The next page of the wizard displays the horizontal alignment or a cross-section plot of the rails based on the selection in the previous screen. This page is purely informative.

Press 'NEXT (F1)' to move to the next page.

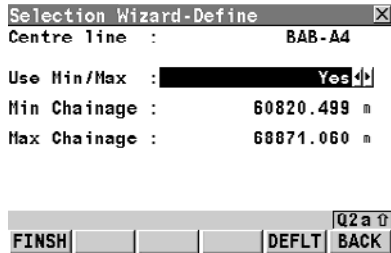

5. This page of the selection wizard defines whether the task should only be applied to a limited section of the alignment. If the defined chainage range is exceeded during stake out/check a warning appears.

**FINSH (F1)**

To complete the selection wizard.

**DEFLT (F5)**

To set the chainage limits to the maximum and minimum chainages available in the rail job.

**BACK (F6)**

To move back to the previous page of the wizard.

## Browsing from a list of existing working tasks

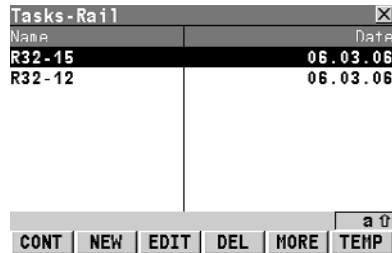

The screenshot shows a window titled 'Tasks-Rail' with a close button. It contains a table with two columns: 'Name' and 'Date'. The first row is highlighted in black and contains 'R32-15' and '06.03.06'. The second row contains 'R32-12' and '06.03.06'. Below the table is a menu bar with buttons for 'CONT', 'NEW', 'EDIT', 'DEL', 'MORE', and 'TEMP'. A small 'a' icon is visible in the top right corner of the menu bar area.

| Name   | Date     |
|--------|----------|
| R32-15 | 06.03.06 |
| R32-12 | 06.03.06 |

CONT NEW EDIT DEL MORE TEMP

A list of all tasks in the internal memory or on the CompactFlash card are available via the tasks browser. The tasks browser may be opened from any point in the program where a task may be selected.

### **CONT (F1)**

To select the highlighted task and continue.

### **NEW (F2)**

To create a new task.

### **EDIT (F3)**

To edit the highlighted task.

### **DEL (F4)**

To delete the highlighted task.

### **MORE (F5)**

To display additional task information.

### **TEMP (F6)**

To create a temporary task. This task is identical to any other task but is not stored for later use.

## Working with shifts

If a shift is defined on the first page of the selection wizard, the parameters associated with the shift must be entered after defining the chainage limits.

The application of the shift is dependent upon to which entity it should be applied: Horizontal alignment or, Vertical alignment. Refer to "8.6 Working with Horizontal Shifts and Vertical Shifts" for details on shifts.

The parameters required for applying the shift are identical for all entities.

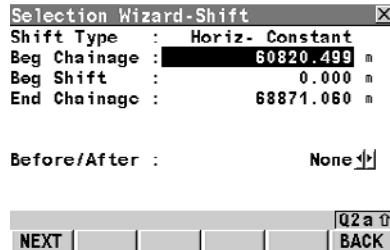

Selection Wizard-Shift

Shift Type : Horiz- Constant

Beg Chainage : 60820.499 m

Beg Shift : 0.000 m

End Chainage : 68871.060 m

Before/After : None

NEXT Q2 a BACK

### For constant shifts:

Beg Chainage:

Chainage from which the shift should be applied.

Beg Shift:

Magnitude of the shift to apply.

End Chainage:

Chainage at which the shift should end.

| Selection Wizard-Shift   |              |  |  |        |  |        |       |  |  |  |      |
|--|--------------|--|--|--------|--|--------|-------|--|--|--|------|
| Shift Type :   | Vert- Linear |  |  |        |  |        |       |  |  |  |      |
| Beg Chainage :   | 60820.499 m  |  |  |        |  |        |       |  |  |  |      |
| Beg Shift :  | 0.000 m      |  |  |        |  |        |       |  |  |  |      |
| End Chainage :   | 68871.060 m  |  |  |        |  |        |       |  |  |  |      |
| End Shift :  | 0.000 m      |  |  |        |  |        |       |  |  |  |      |
| Before/After :   | None         |  |  |        |  |        |       |  |  |  |      |
| <table border="1"> <tr> <td colspan="4"></td> <td>Q2 a 0</td> </tr> <tr> <td>FINSH</td> <td></td> <td></td> <td></td> <td>BACK</td> </tr> </table> |              |  |  |        |  | Q2 a 0 | FINSH |  |  |  | BACK |
|  |              |  |  | Q2 a 0 |  |        |       |  |  |  |      |
| FINSH  |              |  |  | BACK   |  |        |       |  |  |  |      |

**For linear shifts:**

- Beg Chainage:  
Chainage from which the shift should be applied.
- Beg Shift:  
Magnitude of the shift to apply (start chainage).
- End Chainage:  
Chainage at which the shift should end.
- End Shift:  
Magnitude of the shift to apply (end chainage).

## 5.4

### 5.4.1

#### Viewing and Editing

## Viewing and Editing the Design Data

### Overview

The design data stored within the rail job contains all of the information about the rail design. This includes the stringlines and layers. The design data can be viewed and partially edited in these View and Edit screens.

| View&Edit Data |            | ✕    |
|----------------|------------|------|
| Job Name :     | RailJob    |      |
| Layer :        | Rail Layer | ↓↑   |
| #Stringlines : | 1          |      |
| Centre line :  | REast      |      |
| Chainage :     | 50780.840  | m    |
| Ch Increment : | 10.000     | m    |
|                |            | a ↑  |
| CONT           | EDIT       | VIEW |

#### CONT (F1)

To return to the RoadRunner Rail Setup screen.

#### EDIT (F3)

To edit the following design data:

- 1) to edit the general job details,
- 2) to change the start chainage of the centre line of the selected layer.

#### VIEW (F4)

To view the following design data in a selected layer:

- 1) to view specific details of the layer centre line,
- 2) to view cross-section plots.

| Field   | Description of field  |
|---|---|
| <b>Job Name</b>   | The name of the active rail job, as defined in the project.   |
| <b>Layer</b>  | To select a layer from the active rail job. All of the layers within the active rail job can be selected.   |
| <b>#Stringlines</b>   | The number of stringlines from the selected layer.  |
| <b>Centre line</b>  | The name of the layer centre line.  |
| <b>Chainage</b>   | To enter a start chainage to use when viewing the data. The default value is the start chainage of the layer centre line.   |
| <b>Ch Increment</b>   | To enter a chainage increment to use when stepping through the data   |
|  | If a centre line has not been defined, a start chainage cannot be entered and the field will be shown as "----". If a centre line has not been defined, a chainage increment cannot be entered and the field will be shown as "----". |

## 5.4.2

### Viewing details of the layer centre line

## Viewing the Design Data

### This page shows the following:

Geometrical details of the selected stringline at the selected chainage.

| View at 50760.840 |                        |
|-------------------|------------------------|
| Line Tnfn         | Lines Plnt             |
| Line name         | REast                  |
| Easting           | 671430.825 m           |
| Northing          | 7520230.028 m          |
| Height            | 615.713 m              |
| HZ Tangent        | 175.631 g              |
| HZ Radius         | ----- m                |
| HZ Type           | Straight               |
| HZ Offset         | 0.000 m                |
| a tr              |                        |
| CONT              | CH+ CH- SEG HZ/VT PAGE |

#### CONT (F1)

To return to the View&Edit Data screen.

#### CH+ (F2)

To increase the chainage by the chainage increment, as defined in the View&Edit Data screen.

#### CH- (F3)

To decrease the chainage by the chainage increment, as defined in the View&Edit Data screen.

#### SEG (F4)

To enter the Segment Info screen.

#### HZ/VT (F5)

To toggle between the vertical alignment data and the horizontal alignment data.

#### PAGE (F6)

To move to the next page.

| Field  | Description of field                                      |
|--|---|
| Line name  | To select a stringline from the layer.                    |
| Easting  | The East coordinate of the stringline.                    |
| Northing   | The North coordinate of the stringline.                   |
| Height   | The height of the stringline.                             |
| The following fields/values can be toggled, by using the HZ/VT (F5) softkey: |   |
| HZ Tangent/Grade   | The tangent direction or grade of the stringline.         |
| HZ/Vt Radius   | The horizontal/vertical radius of the stringline segment. |

| Field   | Description of field                                     |
|---|--|
| Hz/Vt Type  | The horizontal/vertical segment type.                    |
| Hz/Vt Offset  | The horizontal/vertical offset to the layer centre line. |
|  If a value has not been defined, the field will be shown as "----". |  |

## Viewing a list of all stringlines in the layer

### This page shows the following:

A list of all stringlines in the current layer, their centre line offsets and height differences or absolute heights at the selected chainage.

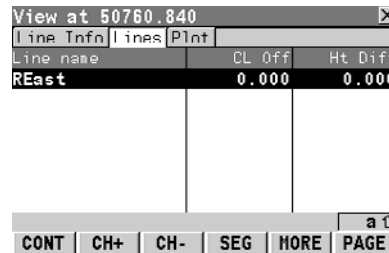

| Line name | CL Off | Ht Diff |
|-----------|--------|---------|
| REast     | 0.000  | 0.000   |

CONT CH+ CH- SEG MORE PAGE

#### CONT (F1)

To return to the View&Edit Data screen.

#### CH+ (F2)

To increase the chainage by the chainage increment, as defined in the View&Edit Data screen.

#### CH- (F3)

To decrease the chainage by the chainage increment, as defined in the View&Edit Data screen.

#### SEG (F4)

To enter the Segment Info screen.

#### MORE (F5)

To toggle between the height differences or absolute heights at the selected chainage.

#### PAGE (F6)

To move to the next page.

#### SHIFT HOME (F2)

To move to the start of the list of stringlines.

#### SHIFT END (F3)

To move to the end of the list of stringlines.



| <b>Column</b>  | <b>Description of column</b>                                      |
|--|---|
| <b>Line Name</b>   | The name of the stringline in the selected layer.                 |
| <b>CL off</b>  | The offset of the stringline from the layer centre line.          |
| The following columns/values can be toggled, by using the MORE (F5) softkey: |   |
| <b>Ht Diff</b>   | The height difference of the stringline to the layer centre line. |
| <b>Height</b>  | The absolute height of the stringline.                            |

## Viewing cross sections

### This page shows the following:

A cross section view of the design data at the selected chainage. No selection or zoom/pan functionality is available.

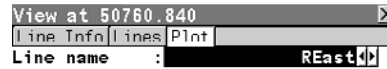

### **CONT (F1)**

To return to the View&Edit Data screen.

### **CH+ (F2)**

To increase the chainage by the chainage increment, as defined in the View&Edit Data screen.

### **CH- (F3)**

To decrease the chainage by the chainage increment, as defined in the View&Edit Data screen.

### **SEG (F4)**

To enter the Segment Info screen.

### **PAGE (F6)**

To move to the next page.

**Viewing the segment:  
the Hz Alignment page**

**This page shows the following:**

Detailed horizontal alignment information about the current stringline segment.

| Segment Info - Start Point |                 |
|----------------------------|-----------------|
| Hz Alignment               | Vt Alignment    |
| Line name                  | : Centreline    |
| Chainage                   | : 132.894 m     |
| Easting                    | : -19859.504 m  |
| Northing                   | : 5301076.311 m |
| Height                     | : 418.963 m     |
| Hz Tangent                 | : 374.7362 y    |
| Hz Radius                  | : 1000000.000 m |
| Hz Type                    | : Clothoid In   |
| a ↑                        |                 |
| CONT                       | SEG+            |
| SEG-                       | ENDP            |
| PAGE                       |                 |

**CONT (F1)**

To return to the View screens.

**SEG+ (F2)**

To move to the next segment.

**SEG- (F3)**

To move to the previous segment.

**ENDP/STRTP (F4)**

To toggle between the start point and the end point of the segment.

**PAGE (F6)**

To move to the next page.

| Field   | Description of field  |
|---|---|
| Line Name   | The name of the selected stringline.                                |
| The following fields/values can be toggled, by using the ENDP/STRTP (F4) softkey: |   |
| Chainage  | The chainage of start/end point of the segment.                     |
| Easting   | The East coordinate of the start/end point of the segment.          |
| Northing  | The North coordinate of the start/end point of the segment.         |
| Height  | The height of the start/end point of the segment.                   |
| Hz Tangent  | The tangent direction at the start/end point of the segment.        |
| Hz Radius   | The radius at the start/end point of the segment (is not toggled).  |
| Hz Type   | The current segment type (is not toggled).                          |
|  | If a value has not been defined, the field will be shown as "----". |

**Viewing the segment:  
the Vt Alignment page**

**This page shows the following:**

Detailed vertical alignment information about the current stringline segment.

| Segment Info - Start Point |                 |
|----------------------------|-----------------|
| Hz Alignment               | Vt Alignment    |
| Line name                  | : Centreline    |
| Chainage                   | : 127.442 m     |
| Easting                    | : -19857.397 m  |
| Northing                   | : 5301071.283 m |
| Height                     | : 419.002 m     |
| Grade                      | : 1:0 hv        |
| Vt Radius                  | : 341.137 m     |
| Vt Type                    | : Circle/Arc    |
| a ↑                        |                 |
| CONT                       | SEG+            |
| SEG-                       | ENDP            |
| PAGE                       |                 |

**CONT (F1)**

To return to the View screens.

**SEG+ (F2)**

To move to the next segment.

**SEG- (F3)**

To move to the previous segment.

**ENDP/STRTP (F4)**

To toggle between the start point and the end point of the segment.

**PAGE (F6)**

To move to the next page.

| Field   | Description of field  |
|---|---|
| <b>Line Name</b>  | The name of the selected stringline.                                |
| The following fields/values can be toggled, by using the ENDP/STRTP (F4) softkey: |   |
| <b>Chainage</b>   | The chainage of start/end point of the segment.                     |
| <b>Easting</b>  | The East coordinate of the start/end point of the segment.          |
| <b>Northing</b>   | The North coordinate of the start/end point of the segment.         |
| <b>Height</b>   | The height of the start/end point of the segment.                   |
| <b>Grade</b>  | The grade at the start/end poin of the segment (is not toggled).    |
| <b>Vt Radius</b>  | The radius at the start/end point of the segment (is not toggled).  |
| <b>Vt Type</b>  | The current segment type (is not toggled).                          |
|  | If a value has not been defined, the field will be shown as "----". |

### 5.4.3

### Editing the Design Data

#### Editing the job details

The screenshot shows a terminal window titled 'Edit: RailJob'. The 'Name' field is set to 'RailJob'. The 'Description' field is empty, indicated by four dashes. The 'Creator' field is set to 'ORG'. The 'Device' field is set to 'CF Card'. At the bottom, there are two buttons: 'STORE' and 'PAGE', with a cursor positioned over the 'PAGE' button.

#### STORE (F1)

To return to the View&Edit Data screen.

#### PAGE (F6)

To move to the next page.

| Field              | Description of field   |
|--------------------|--|
| <b>Name</b>        | The unique name of the rail job. The name may be up to 16 characters long and may include spaces. This field is mandatory. |
| <b>Description</b> | A detailed description of the rail job (two lines are available). This field is optional.                                  |
| <b>Creator</b>     | The name of the person who created the rail job. This field is optional.   |
| <b>Device</b>      | CF Card or Internal Memory. The device on which the rail job is stored.  |

## Changing the start chainage of the centre line of the selected layer

```

Edit: Rail Layer
|Inb| Centreline |
Centreline : REast
StartChainage: 50760.840 m
End Chainage : 53810.410 m
    
```

```

| a ↑
STORE | | RESET | | PAGE
    
```

| Field                | Description of field  |
|----------------------|---|
| <b>Centreline</b>    | The name of the centre line.  |
| <b>StartChainage</b> | To enter a start chainage for the layer centre line. By using the centre line length, the end chainage is automatically calculated. |
| <b>End Chainage</b>  | The end chainage of the layer centre line, as calculated from the start chainage.   |

### STORE (F1)

To store data and return to the View&Edit Data screen.

### RESET (F4)

To clear all changes made to the start chainage reset to the original start chainage.

### PAGE (F6)

To move to the next page.

# 6

## 6.1

### Configuration settings

# Configuring

## Overview of all Configuration Settings

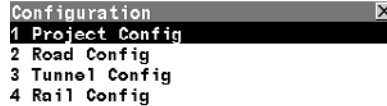

The configuration of the RoadRunner program is divided into five parts:

1. Project configuration
2. Road configuration
3. Tunnel configuration
4. Rail configuration



| Screen                | Description   |
|-----------------------|---|
| <b>Project Config</b> | These configuration settings refer to general parameters that apply to all projects (road, tunnel and rail projects). They define the appearance and behaviour common for all parts of the RoadRunner program.  |
| <b>Road Config</b>    | These configuration settings refer to parameters that apply only to Road projects.  |
| <b>Tunnel Config</b>  | These configuration settings refer to parameters that apply only to Tunnel projects.  |
| <b>Rail Config</b>    | These configuration settings refer to parameters that apply only to Rail projects. The Rail configuration consists of four pages where parameters relating to the configuration of the program may be modified. |

## 6.2

### 6.2.1

#### The General page

## Configuration Settings for the Project - Project Config

### The General Page

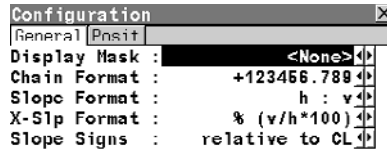

#### CONT (F1)



To confirm the changes and continue.



| Field        | Option        | Description of Field  |
|--------------|---------------|---|
| Display Mask | Chocelist     | Selects the user defined display mask shown in the RoadRunner program for all stake out and check methods. All display masks of the active configuration set can be selected. |
|              |               |   |
| Chain Format |               | Selects display format for all chainage information fields.   |
|              | +123456.789   | Default chainage display form.  |
|              | +123.4+56.789 | Separator between tens and hundreds with additional decimal point.  |
|              | +123+456.789  | Separator between hundreds and thousands.   |
|              | +1234+56.789  | Separators between tens and hundreds.   |



| Field               | Option                                | Description of Field  |
|---------------------|---------------------------------------|---|
|                     |                                       | The distance units Int Ft/Inch (fi) >, US Ft/Inch (ft) >, Kilometres (km) > and US Miles (mi) > are only supported by the first chainage format. All other chainage formats are restricted to the base units Metre (m) >, Int Ft (fi) > and US Ft (ft) >. |
| <b>Slope Format</b> |                                       | Selects the display format for all slope values.  |
|                     | h:v                                   | Horizontal:Vertical; for example 5:2.   |
|                     | v:h                                   | Vertical:Horizontal; for example 2:5.   |
|                     | % (v/h * 100)                         | For example 40%.  |
|                     | Elev Angle                            | Angle, format depends upon system configuration. For example 21.8014 deg, 21°48'05", 24.2238 gon. Refer to the TPS1200 Technical Reference Manual for details on available angle formats.   |
| <b>X-Slp Format</b> | h:v, v:h, % (v/h * 100) or Elev Angle | Same as Slope Format. Refer to " Slope Format" above.   |
| <b>Slope Signs</b>  |                                       | Selects sign definition method for slopes and X-slopes.   |
|                     | mathematical                          | All slopes sign defines from left to right, independent of whether left or right of the centre line.  |

| Field                                | Option  | Description of Field   |
|--------------------------------------|---|--|
| relative to CL /<br>relative from CL | Slope signs defined relative to/from the centre line. | <div style="display: flex; justify-content: space-around;"> <div style="text-align: center;"> <p>relative to CL</p>  </div> <div style="text-align: center;"> <p>relative from CL</p>  </div> </div> <div style="text-align: center; margin-top: 10px;"> <p>mathematic</p>  </div> <p>RR12_054</p> |

## 6.2.2

### The Posit page

### The Posit Page (TPS only)

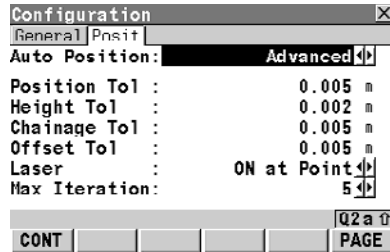

The Auto position allows the instrument to aim at the position to stake out. Refer to "6.4 Auto Positioning (TPS only)" for details on the different positioning types. This functionality is only available for motorised instruments.

#### CONT (F1)

To confirm the changes and continue.

#### PAGE (F6)

To move to the next page.

| Field                | Option           | Description of Field   |
|----------------------|------------------|--|
| <b>Auto Position</b> | NONE             | No auto position.  |
|                      | 2D (Hz)          | Instrument positions horizontally.   |
|                      | 3D (Hz & V)      | Instrument positions horizontally and vertically.  |
|                      | 2D + Meas        | Instrument positions horizontally and finds the height by iterative distance measurements. Refer to "6.4.2 Auto Position 2D + Measure (TPS only)". |
|                      | Advanced         | Allows to keep certain values of the current position to remain constant. Refer to "6.4.3 Auto Position Advanced (TPS only)".                      |
|                      |                  | The following lines will only be enabled for Auto Position: 2D + Meas > or Auto Position: Advanced >.  |
| <b>Position Tol</b>  | From 0.001 to 10 | 2D distance tolerance to the position to stake out.  |

| Field                | Option           | Description of Field   |
|----------------------|------------------|--|
| <b>Height Tol</b>    | From 0.001 to 10 | Height tolerance of the position to stake out.   |
| <b>Chainage Tol</b>  | From 0.001 to 10 | Chainage tolerance of the position to stake out.   |
| <b>Offset Tol</b>    | From 0.001 to 10 | Offset tolerance of the position to stake out.   |
| <b>Laser</b>         |                  | Defines when the red laser is turned on during the automatic search of the position.   |
|                      | Always off       | Visible red laser is turned off.   |
|                      | On at Point      | Visible red laser is turned on as soon as the point is found.  |
|                      | Always on        | Visible red laser is turned on during the whole search.  |
|                      |                  | The laser can also be permanently turned on by using the instrument settings. Refer to the TPS1200 Technical Reference Manual for details. |
| <b>Max Iteration</b> | From 2 to 10     | Maximum number of iterations for the distance measurement before stopping.   |

## 6.3

### 6.3.1

#### The General page

## Configuration Settings for the Program - Rail Config

### The General Page

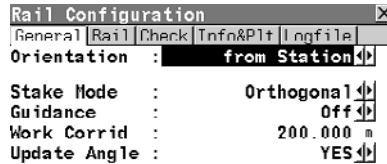

The General page allows parameters that will be used throughout the program to be set.

#### CONT (F1)

To confirm the changes and continue.

#### PAGE (F6)

To move to the next page.

| Field              | Description of Field  |
|--------------------|---|
| <b>Orientation</b> | <p>The reference direction used to stake out points. The stake out elements and the graphics displayed are based on this selection:</p> <hr/> <p>To Alignment:<br/>The position of the measured point and the calculated differences are displayed relative to the alignment.</p> <hr/> <p>To North:<br/>The north direction of the active coordinate system is used as the reference direction.</p> <hr/> <p><input type="checkbox"/> GPS To Sun:<br/>The position of the sun calculated from the current position, the time and the date.</p> <hr/> |

| Field             | Description of Field  |
|-------------------|---|
|                   | <p>[GPS] To Last point:<br/>Timewise the last recorded point.</p>   |
|                   | <p>[GPS] To Known Point:<br/>A point from the 'Meas Job' is selected.</p>   |
|                   | <p>To Arrow:<br/>The direction of the orientation is from the current position to the position to stake out. The graphic displays a moving arrow pointing in the direction of the position to stake out.</p>  |
|                   | <p>[TPS] From Station:<br/>The position of the measured point and the calculated differences are displayed relative to the position of somebody located at the sensor looking towards the measured point.</p>   |
|                   | <p>[TPS] To Station:<br/>The position of the measured point and the calculated differences are displayed relative to the position of somebody located at the measured point looking towards the sensor.</p>   |
| <b>Stake Mode</b> | <p>If the option To Station or From Station is used, the displayed differences between the measured point and the design point may be configured:</p> <p>Orthogonal:<br/>The differences are displayed as two orthogonal distances left/right and forward / back with respect to the line of sight.</p> |

| Field                | Description of Field   |
|----------------------|--|
|                      | <p>Polar:<br/>The differences are displayed as polar coordinates, angle and distance, with respect to the line of sight.</p>   |
| <b>Guidance</b>      | <p>Indication of direction and distance from measured point to point to set out:</p> <hr/> <p>Off:<br/>No graphical guidance is used, only numerical values are available on the screen.</p> <hr/> <p>Arrows:<br/>Forward / Back and Left / Right arrows are shown on the screen.</p> <hr/> <p>Graphics:<br/>A bulls-eye is shown on the screen.</p> <hr/> <p>Arrows&amp;Graphics:<br/>Forward / Back and Left / Right arrows and a bulls-eye are shown on the screen.</p> |
| <b>Work Corridor</b> | <p>Working corridor of rail job. If a measured point is further away from the working corridor distance, an error message is displayed.</p>  |
| <b>Update Angle</b>  | <p><span style="border: 1px solid black; padding: 2px;">TPS</span> Update of vertical angle after a distance measurement.</p>  |

| Field | Description of Field   |
|-------|--|
|       | <p>Yes:<br/>Update vertical angle and height measurement when the vertical angle is changed after a distance measurement has been made.</p>            |
|       | <p>No:<br/>Angles and stake out values are updated only after a distance measurement. All values are then frozen until the next distance is taken.</p> |



## 6.3.2

## The Rail Page

### The Rail page

| Rail Configuration |              |
|--------------------|--------------|
| General            | Rail         |
| SuperElv_Base:     | 1.500 m      |
| Nominal Gauge:     | 1.435 m      |
| Calc Chainage:     | Direct Chain |
| Offsets:           | Manual       |
| Use Cant:          | Yes          |
| CL Height:         | CL Geometry  |

|      |  |  |  |         |
|------|--|--|--|---------|
|      |  |  |  | Q2 a tr |
| CONT |  |  |  | PAGE    |

The Rail page allows track specific parameters to be set.

#### CONT (F1)

To confirm the changes and continue.

#### PAGE (F6)

To move to the next page.

| Field                | Description of Field   |
|----------------------|--|
| <b>SuperElv_Base</b> | Distance over which the superelevation is to be applied. This distance normally corresponds to the distance between the rail axes. |
| <b>Nominal Gauge</b> | Nominal distance between the active (internal) faces of the left and right rails.  |

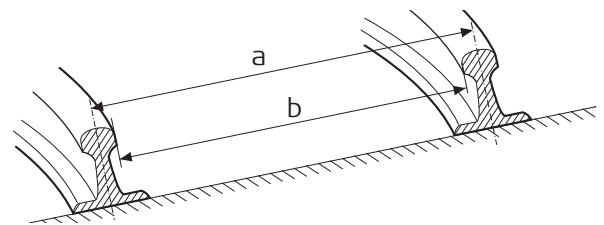

a) superelevation base  
a) nominal guage

| <b>Field</b>         | <b>Description of Field</b>   |
|----------------------|---|
| <b>Calc Chainage</b> | <p data-bbox="903 127 1501 398">When working with multiple tracks, it is sometimes the case that the chainage of the measured point should be calculated with respect to a chainage centre line after having been projected first onto the track centre line, this is known as the indirect measurement method. If the chainage is calculated by projecting the measured point directly onto the chainage centre line, this is called the direct measurement method.</p> <p data-bbox="903 434 1501 521">Chainage calculation method when checking points multiple tracks with respect to a chainage centre line.</p> |

**Field****Description of Field****Method 1: Direct Chainage**

Project measured point directly onto the chainage centre line.

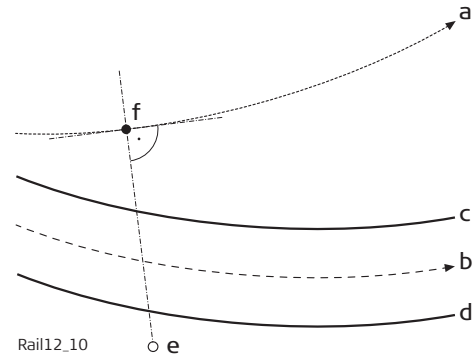

- a) chainage centre line
- b) track centre line
- c) left rail
- d) right rail
- e) measured point
- f) direct chainage

**Field****Description of Field****Method 2: Indirect Chainage**

Project measured point onto track centre line and then make a second projection onto the chainage centre line.

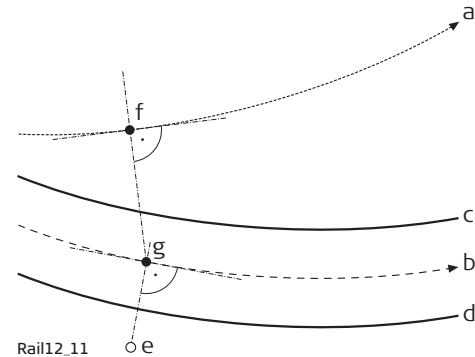

- a) chainage centre line
- b) track centre line
- c) left rail
- d) right rail
- e) measured point
- f) measured point projected onto track centre line
- g) indirect chainage

| Field            | Description of Field   |
|------------------|--|
| <b>Offsets</b>   | Type of offsets to be used for staking out points and checking points.   |
|                  | <p>Manual:<br/>Enter offsets manually.</p> <p>From Library:<br/>Select offsets from offset library.</p>                              |
| <b>Use Cant</b>  | If the rail job does not contain a rail definition (superelevation), the cant of the rail may be defined manually (Yes) or not (No). |
| <b>CL Height</b> | <p>CL Geometry:<br/>The CL height is taken from the alignment centre line.</p>   |
|                  | <p>Rail Interpolated:<br/>The CL height is interpolated between the left rail height and right rail height.</p>                      |

### 6.3.3

## The Check Page

### The Check page

Rail Configuration

General Rail Check Info&Plt Logfile

Quality Check: Ch&Off&Ht

Chainage Tol : 0.020 m

Offset Tol : 0.020 m

Height Tol + : 0.020 m

Height Tol - : -0.020 m

Position Tol : 0.020 m

Beep near Pt : On

Dist from Pt : 0.500 m

Q2 a r

CONT PAGE

The Check page allows parameters that will be used during Rail Check to be set.

#### CONT (F1)

To confirm the changes and continue.

#### PAGE (F6)

To move to the next page.

| Field         | Description of Field   |
|---------------|--|
| Quality Check | Activates a position check when storing a staked or checked point. When the defined tolerance is exceeded, the stake out/check can be repeated, skipped or stored. Depending on this selection the lines below are enabled/disabled. |
|               | NONE:<br>No quality check during stake out/check of points.  |
|               | Ch&Off&Ht:<br>Check for chainage, horizontal offset and height.  |
|               | Ch&Off:<br>Check for chainage and horizontal offset.   |
|               | Pos&Ht:<br>Check for 2D position and height.   |
|               | Position:<br>Check for 2D position.  |

| Field               | Description of Field  |
|---------------------|---|
|                     | Height:<br>Check for height.  |
| <b>Chainage Tol</b> | From 0.001 to 100 Maximum permitted difference in chainage between the measured and design point.   |
| <b>Height Tol ↑</b> | From 0.001 to 100 Maximum permitted horizontal offset from defined position.  |
| <b>Height Tol ↓</b> | From 0.001 to 100 Maximum permitted height difference above the defined position.   |
| <b>Height Tol</b>   | From 0.001 to 100 Maximum permitted height difference below the defined position.   |
| <b>Position Tol</b> | From 0.001 to 100 Maximum permitted radial horizontal distance.   |
| <b>Beep near Pt</b> | On or Off Activates an acoustic warning signal when the horizontal radial distance from the current position to the point to stake out is equal or less than defined in Dist from Pt. |
| <b>Dist from Pt</b> | Available when Beep near Pt: On is selected. Defines the horizontal radial distance from the current position to the design point within which the acoustic warning signal is active. |

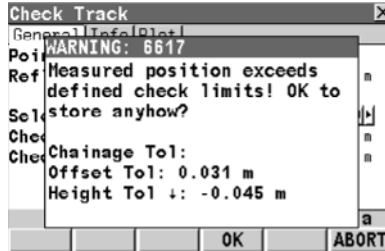

If tolerance values have been set in the program configuration, RailRunner compares the position of the measured values with the design values when a point is recorded using the ALL (F1) or REC (F3) key. If the difference between the measured and design values is greater than the specified tolerance, a warning message is displayed, advising the user that the point is out of tolerance.

The point may be recorded anyway by pressing the OK (F4) key or rejected by pressing the ABORT (F6) key.



### 6.3.4

### The Info&Plot Page

#### The Info&Plot page

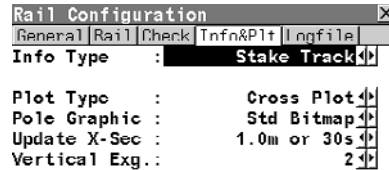

The Info and Plot page allows the definition of the parameters to be seen on the Info page whilst working with the program. It also allows the parameters to be used for plotting functions to be defined.

#### **CONT (F1)**

To confirm the changes and continue.

#### **EDIT (F3)**

To edit the parameters of the active 'Info' page.

#### **PAGE (F6)**

To move to the next page.

| Field            | Description of Field   |
|------------------|--|
| <b>Info Type</b> | Defines the parameters to view on the Info page of the program. Different combinations of the parameters to view may be stored for the two main functions of the program: Check Track and Stake Track. |
| <b>Plot Type</b> | Defines the type of plot to be viewed on the Plot page.<br><br>Cross Plot:<br>View measured point with respect to design profile.  |

| Field               | Description of Field  |
|---------------------|---|
|                     | <p>Plan View:<br/>View position of measured point with respect to horizontal alignment.</p> <hr/> <p>Profile View:<br/>View position of measured point with respect to vertical alignment.</p>  |
| <b>Pole Graphic</b> | <p>Defines the graphical representation of the measured point on the plot page.</p> <hr/> <p>Std Bitmap:<br/>Standard bitmap image of a reflector and pole.</p> <hr/> <p>Actual Height:<br/>Reflector pole is not shown and position of reflector denotes the actual measured position.</p>   |
| <b>Update X-Sec</b> | <p>Update frequency of the cross section view on the Plot page when working in tracking mode.</p> <hr/> <p>0.5m or 2s:<br/>Update the plot every 2 seconds or when the measured point is more than 0.5m from the previous plotted point.</p> <hr/> <p>0.5m or 10s:<br/>Update the plot every 10 seconds or when the measured point is more than 0.5m from the previous plotted point.</p> |

| Field               | Description of Field  |
|---------------------|---|
|                     | <p>1.0m or 30s:<br/>Update the plot every 30 seconds or when the measured point is more than 1 metre from the previous plotted point.</p>   |
|                     | <p>5.0m or 1m:<br/>Update the plot every 60 seconds or when the measured point is more than 5 metres from the previous plotted point.</p>   |
| <b>Vertical Exg</b> | <p>Vertical exaggeration for cross section plots.<br/>Vertical plot scale relative to horizontal.</p> <p>0.5:<br/>Ratio of vertical to horizontal scale 1:2</p> <p>1:<br/>Ratio of vertical to horizontal scale 1:1</p> <p>2:<br/>Ratio of vertical to horizontal scale 2:1</p> <p>5:<br/>Ratio of vertical to horizontal scale 5:1</p> <p>10:<br/>Ratio of vertical to horizontal scale 10:1</p> |

## Defining the Info page

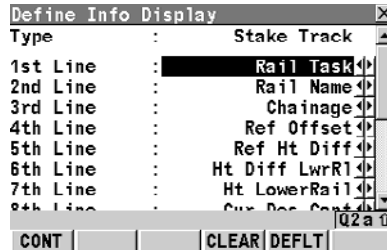
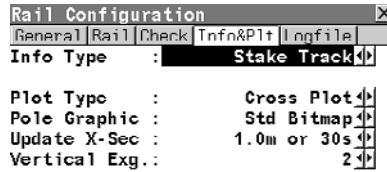

1. The Define Info Display page allows the parameters to view on the Info page of the program to be defined. Different combinations of the parameters to view may be stored for the main functions of the program: Check Track and Stake Track. The process for defining each of these combinations is identical. The user defines which parameter should be viewed on each line. Up to 16 lines of parameters may be defined although a maximum of 9 lines may be viewed at any one time. It is necessary to scroll with the arrow keys to view additional lines.

2. To modify the selection on any particular line, place the cursor on the line to modify using the arrow keys and press the Enter key. Use the arrows key select the required parameter and press the Enter key to confirm the choice. It is also possible to search for a parameter by entering the first character of the parameter name.

### CONT (F1)

To confirm the changes and continue.

### CLEAR (F4)

To clear all parameters from all lines.

### DEFLT (F5)

To set the default value for all lines.

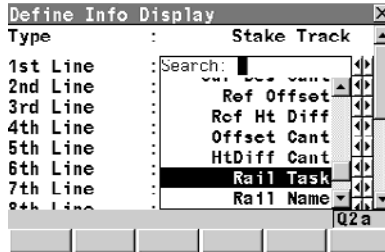

- To modify the selection on any particular line, place the cursor on the line to modify using the arrow keys and press the Enter key. Use the arrows key select the required parameter and press the Enter key to confirm the choice. It is also possible to search for a parameter by entering the first character of the parameter name.

**CONT (F1)**

To confirm the changes and continue.

**CLEAR (F4)**

To clear all parameters from all lines.

**DEFLT (F5)**

To set the default value for all lines.

The following parameters are available:

| Field               | Description of Field   |
|---------------------|--|
| <b>ΔOffset</b>      | Distance from the measured point to the point to set out in a direction perpendicular to the horizontal alignment. |
| <b>ΔHeight</b>      | Height difference between the measured point and the point to set out.   |
| <b>ΔChainage</b>    | Chainage difference between the measured point and the point to set out.   |
| <b>Act Easting</b>  | Easting of the measured point.   |
| <b>Act Northing</b> | Northing of the measured point.  |

| <b>Field</b>        | <b>Description of Field</b>  |
|---------------------|--|
| <b>Act Height</b>   | Height of the measured point.  |
| <b>Chainage</b>     | Chainage of the measured point.  |
| <b>CL Grade</b>     | Grade of the vertical alignment at the chainage of the measured point.   |
| <b>CL Height</b>    | Height of the vertical alignment at the chainage of the measured point.  |
| <b>CL Ht Diff</b>   | Height difference between the measured point and the height of the vertical alignment at the same chainage.                |
| <b>CL Offset</b>    | Distance between the measured point and the horizontal alignment in a direction perpendicular to the horizontal alignment. |
| <b>CL Radius</b>    | Radius of the horizontal alignment at the at the chainage of the measured point.   |
| <b>CL Tangent</b>   | Direction of the tangent to the horizontal alignment at the at the chainage of the measured point.                         |
| <b>CL Type</b>      | Curve type of the horizontal alignment at the chainage of the measured point.  |
| <b>Def Easting</b>  | Easting of the point to set out.   |
| <b>Def Northing</b> | Northing of the point to set out.  |
| <b>Def Height</b>   | Height of the point to set out.  |

| <b>Field</b>           | <b>Description of Field</b>   |
|------------------------|---|
| <b>Dirc to Point</b>   | Direction from the measured point towards the point to set out.                                       |
| <b>Dist to Point</b>   | Horizontal distance from the point to the point to set out.   |
| <b>Ht Diff LwrRI</b>   | Height difference between the measured point and the lowest rail                                      |
| <b>Ht LowerRail</b>    | Height of the lowest rail   |
| <b>Line Space Full</b> | Empty full line   |
| <b>Line Space Half</b> | Empty half line.  |
| <b>Near Tang Pt</b>    | Distance along the horizontal alignment from the measured point to the nearest tangent point.         |
| <b>Quality 3D</b>      | Standard deviation of the point measurement.  |
| <b>Rail Name</b>       | Name of the centre line or rail being used as a reference.  |
| <b>Rail Task</b>       | Name of the current task  |
| <b>Ref Ht Diff</b>     | Height difference between the measured point and the rail or centre line being used as a reference.   |
| <b>Ref Offset</b>      | Horizontal distance between the measured point and the rail or centre line being used as a reference. |
| <b>Cur Des Cant</b>    | Design cant at the current position.  |

| <b>Field</b>        | <b>Description of Field</b>   |
|---------------------|---|
| <b>Current Cant</b> | Superelevation of the current position. This is calculated by using the 'Second Point of Cant' option, which is located in the Extras Menu. |
| <b>Def Des Cant</b> | Design cant at the defined chainage.  |
| <b>HtDiff Cant</b>  | Height difference cant.   |
| <b>Offset Cant</b>  | Offset cant.  |



## 6.3.5

### The Logfile page

### The Logfile Page

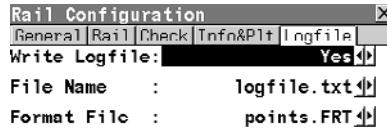

The Logfile page allows the user to define the name and format of any log file that should be written. Data is recorded to the logfile each time a data is recorded to the database. The format of the log file is determined by the selected format file. Format files may be defined in the Format Manager component of the Leica Geo Office program.

#### **CONT (F1)**

To confirm the changes and continue.

#### **PAGE (F6)**

To move to the next page.

| Field         | Description of Field   |
|---------------|--|
| Write Logfile | Defines whether a log file should be written or not.   |
| File Name     | Name of log file to be written. Log files are stored in the folder named DATA on the CF memory card. |
| Format File   | Format file to use when writing the log file.  |

## 6.4

### 6.4.1

#### Description

## Auto Positioning (TPS only)

### Overview (TPS only)

To make stake out of points even more efficient a motorised instrument offers you the possibility to automatically aim to the stake out position. Various auto positioning methods are available:

| Type             | Description   |
|------------------|---|
| <b>2D</b>        | The instrument positions horizontally in the direction of the point to stake out. |
| <b>3D</b>        | The instrument positions horizontally and vertically to the point to stake out.   |
| <b>2D + Meas</b> | Positions the instrument using iterative measurements.                            |
| <b>Advanced</b>  | Offers the possibility of fixing certain stake out values.                        |

When using the 3D method the instrument will only point to the correct position on the ground if the point to stake out has the same height as the natural surface. If the natural surface is higher than the point to stake out, the measured point would be closer than the stake out point. If the natural surface is lower than the point, the measured point would be further away.

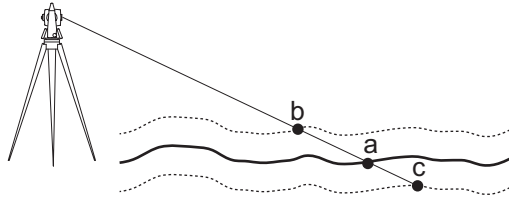

RR12\_071

- a) Point to stake out, defined with 3D coordinates
- b) Position if natural surface is higher than point to stake out
- c) Position if natural surface is lower than point to stake out

To avoid this problem RoadRunner offers the possibility of iterative positioning using the auto position method 2D + Meas.

---

## 6.4.2

### Auto Position 2D + Measure (TPS only)

#### Description

This auto position method 2D + Meas allows the instrument to aim at a 2D position. As the natural surface height is unknown the correct position is calculated via iterations.

#### Workflow

The first position (b) the instrument points to is defined by the 2D coordinates (a) of the point to stake out (= horizontal direction) and the current vertical angle. Therefore, aim the instrument at the approximate position of the point to stake out.

RoadRunner then compares the measured 2D position with the stake out position to determine a new position (c) to aim at. As no information about the natural surface is available, RoadRunner calculates a point at the same height as the measured position. The new position (d) is measured and compared again with the point to stake out (a).

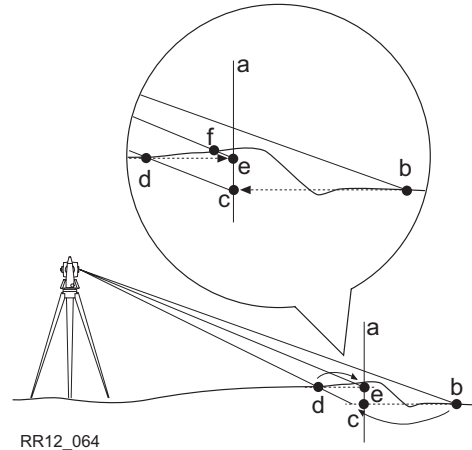

This iteration process runs until the tolerances defined for the stake out are reached.



- a) 2D position to stake out
- b) First position measured defined by 2D coordinates and current vertical angle
- c) New position calculated based on height of b
- d) Second position measured
- e) New position calculated base on height of d. The measured position for this point is within the defined tolerance, the correct position is found.

Depending on the settings chosen on RoadRunner Configuration, Posit page the instrument will turn on the red laser as soon as the position is found.

## Auto position step-by-step

| Step  | Description  |
|---|--|
| 1.  | Press <b>PAGE (F6)</b> until the Posit page is active.   |
| 2.  | RoadRunner Configuration, Posit page.<br>Choose Auto Position: 2D + Meas >.  |
|  | Make sure that the instrument uses the reflectorless EDM mode.   |
| 3.  | As the instrument uses the current vertical angle for the first iteration aim the instrument at the position you expect the point to stake out.  |
| 4.  | Press <b>SHIFT POSIT (F4)</b> to start the iterative positioning of the instrument.  |
|  | The instrument spins to the horizontal direction and uses the current vertical angle for the first iteration. As soon as the defined Position Tol from RoadRunner Configuration, Posit is reached, the instrument stops. |
|  | Depending on the settings chosen on RoadRunner Configuration, Posit page, the instrument turns on the red laser to mark the height.  |

### 6.4.3

### Auto Position Advanced (TPS only)

#### Description

The advanced option for auto positioning allows you to let the instrument aim at positions with certain parameters fixed. For example, let the instrument find the height on the peg.

#### Auto position step-by-step

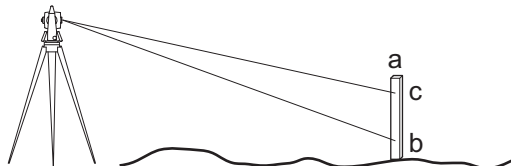

In this example, the height of the X-slope should be marked on a peg by using the auto position function.



RR12\_072

- a) Peg placed at the correct position
- b) First height, manually chosen direction
- c) Required height on the peg

| Step  | Description   |
|---|---|
| 1.  | Press <b>PAGE (F6)</b> until the Posit page is active.  |
| 2.  | RoadRunner Configuration, Posit page.<br>Choose Auto Position: Advanced >.                                      |
|  | Make sure that the instrument uses the reflectorless EDM mode.  |
| 3.  | After stake out of the peg at the correct position with RoadRunner Stake X-Slope aim the instrument at the peg. |
| 4.  | Press <b>SHIFT POSIT (F4)</b> to start the iterative positioning of the instrument.                             |
| 5.  | RoadRunner Auto Position<br>Highlight Height (Dir = fixed).   |

| Step  | Description   |
|---|---|
| 6.  | Press <b>CONT (F1)</b>  |
|  | The instrument will search for the point on the peg at the required height without changing the horizontal direction.               |
|  | As soon as the defined Height Tol from RoadRunner Configuration, Posit is reached, the instrument stops.                            |
|  | Depending on the settings chosen on RoadRunner Configuration, Posit page, the instrument turns on the red laser to mark the height. |

### Using Rail Editor

| Step | Description  |
|------|--|
| 1.   | <p><b>Introducing the program.</b></p> <p>Rail design data may be entered manually on-board the sensor or created using the Rail Editor PC program. This program is integrated into the 'Design to Field' converters.</p> <p>A superelevation file can be obtained in the following ways:</p> <ul style="list-style-type: none"><li>• by selecting an existing superelevation file.</li><li>• by selecting an existing superelevation file and modifying it with Rail Editor.</li><li>• by creating a new superelevation file with Rail Editor.</li></ul> <p>Design data which is compulsory:<br/>A track design must contain a horizontal alignment.</p> <p>Design data which is optional:<br/>A track design may include a vertical alignment and a rail definition (superelevation). Superelevation is only possible when the track design includes a vertical alignment.</p> |

---



| Step | Description |
|------|-------------|
|------|-------------|

2. **Starting the program.**



To create a rail definition (superelevation) for any track, click the 'Edit' button next to the Superelevation file name. This will start the 'Rail Editor' program.

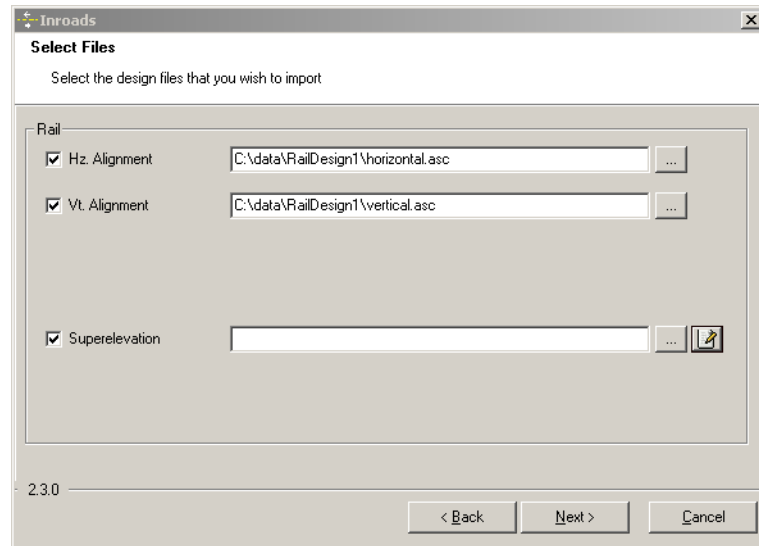

| Step | Description |
|------|-------------|
|------|-------------|

|    |                           |
|----|---------------------------|
| 3. | <b>Using the program.</b> |
|----|---------------------------|

The 'Rail Editor' program is used to define the height of the rails at a given chainage. The height of the rails may be defined by a rotation point and a cant or by a left and right cant.

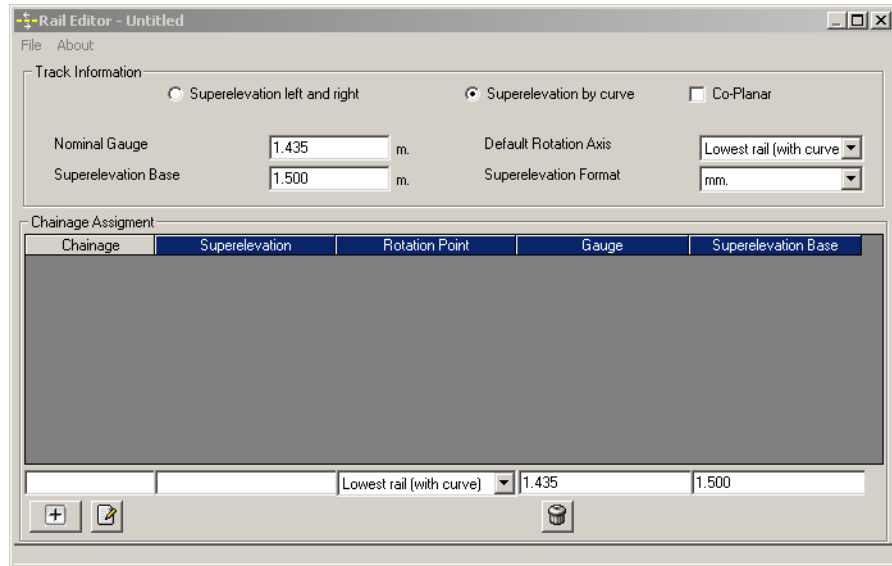

---

### Describing the screen elements - Entering Track Information

---

Superelevation left and right To define the height of the rails using one superelevation value for the left rail and another superelevation value for the right rail.

Superelevation by curve To define the rails using a rotation point and a superelevation value.



Once the method by which the superelevation values will be defined has been selected, it cannot be changed

---



Co-Planar (for multiple tracks) To define the height of the rails of the second track by extending the plane which runs through the rails of the first track.

Nominal Gauge The default nominal distance between the active (internal) faces of the left and right rails. This value may be changed if required for part any rail definition (superelevation).

Superelevation Base The distance over which the superlevation is applied. This is normally the distance between the centre of the left and right rail. This value may be changed if required for any rail definition (superelevation).

---

|                       |   |
|-----------------------|---|
| Default Rotation Axis | If a rotation point is used, this selection will be used as the default for all new rail definitions. This value may be changed if required for any rail definition (superelevation). |
| Superelevation Format | The format in which the superelevation values will be entered.  |

| Step | Description   |
|------|---|
| 4.   |  Once all superelevation data has been entered, press the button to add the data to the chainage assignment panel. |
|      |  To delete an element, select the element and press the button.  |
|      |  To modify an existing element, select the element, modify the data and press the button.                          |
|      | Once all values have been entered for the entire alignment, the file can be saved in an XML format using the Save option of the File menu.  |
|      | To return to the Design To Field converter, select Exit from the File menu.   |
|      | To modify an existing rail definition (superelevation) file (example, XML Files), use the 'Load' option of the File menu to load the file.  |

# 8 Understanding the Terms and Expressions

## 8.1 Overview

### Description of the program

- The RoadRunner Rail program is a loadable program for GPS1200 receivers and TPS1200 total stations. This program enables the user to perform railway specific survey tasks.
- The RoadRunner Rail program is an add-on component of the RoadRunner group of programs. Before starting, it is necessary that both RoadRunner and RoadRunner Rail are loaded onto the receiver/instrument.
- Both RoadRunner and RoadRunner Rail programs are licence protected. They may be activated through a licence key which is specific to the receiver/instrument. This licence key may be entered either through the Main Menu: Tools...\Licence Keys or alternatively, the first time the program is started.

### The main functions of the program

- The RoadRunner Rail program consists of two main functions.

| Function       | Description   |
|----------------|---|
| Rail Check     | For checking or measuring an existing track and comparing the measurements against design data. |
| Rail Stake-Out | For setting or staking out and adjusting track features during construction using design data.  |

### Definition of a track

- A track comprises two separate rails.

## **Importing the track design**

- Single track or multiple track designs may be imported for use with this program.
  - The horizontal and vertical alignments of the track design may be imported either by:
    - using the industry standard LandXML data format, or
    - using one of a number of other road and rail design packages, in conjunction with the Design to Field component of LEICA Geo Office.
  - For multiple track designs, it is possible to define one centre line which is common to all tracks.
- 

## **Using superelevation tables**

- A superelevation table may be created for each track with the Road Editor PC program, which is a part of the Design to Field component in LEICA Geo Office.
- 

## **Terms and expressions**

- In order to make the following chapters on track staking and track checking easier to understand, the basic terminology is introduced throughout this chapter.
  - It is important to be aware that the terminology and/or workflow used on different construction sites may vary from those used in this manual. The underlying principles however, remain the same.
-

## 8.2

## Working with a Single Track

### Description

- Single tracks are defined as one track with one centre line and two rails.
- All chainages are calculated from the centre line.

### Diagram - Plan

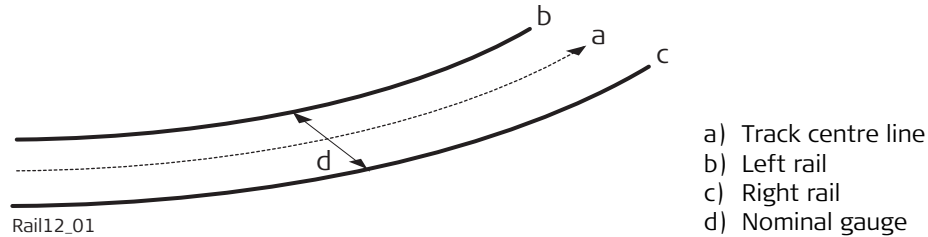

### Diagram - Section

Two generic methods may be used to define the section of the track.

#### Method 1 - a definition using rotation around a known point

This method involves rotating the section around a known point, normally the lowest rail.

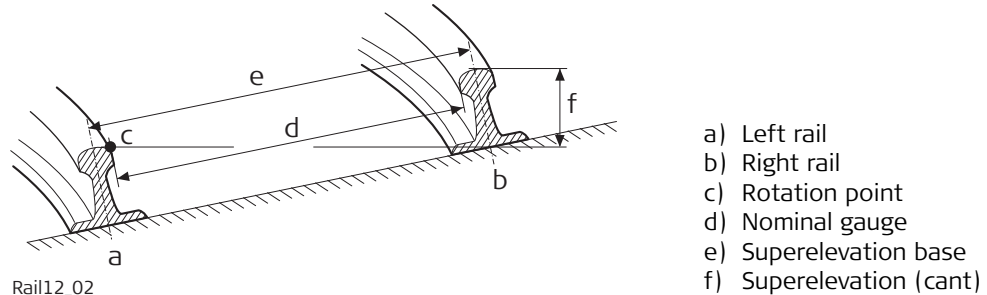

## Method 2 - a definition using relative height distances

This method uses height differences relative to the vertical alignment to define the height of the left and right rail.

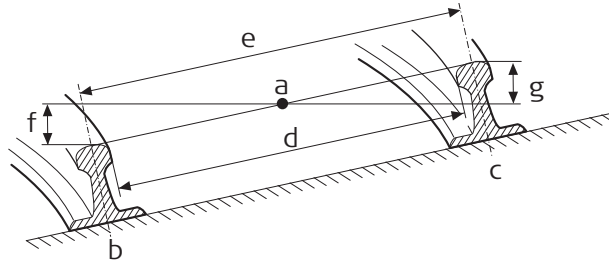

Rail12\_03

- a) Track centre line
- b) Left rail
- c) Right rail
- d) Nominal gauge
- e) Superelevation base
- f) Left superelevation (left cant)
- g) Right superelevation (right cant)

## Terms and expressions

| Term / Expression          | Description  |
|----------------------------|--|
| <b>Track centre line</b>   | <ul style="list-style-type: none"> <li>Geometric alignment in two or three dimensions to which all design elements of the project are referenced. It may be that the vertical component of the alignment does not coincide with the plan component. In this case the vertical part of the alignment will generally coincide with the lowest rail.</li> </ul> |
| <b>Chainage or Station</b> | <ul style="list-style-type: none"> <li>The cumulative distance along the centre line, frequently but not always starting at zero.</li> </ul>   |
| <b>Left/Right rail</b>     | <ul style="list-style-type: none"> <li>Planimetric position of the left/right rail of a track.</li> <li>The sense of the left/right rail is given by the direction of increasing chainage.</li> </ul>  |



| Term / Expression  | Description   |
|--|---|
| <b>Nominal gauge</b>                                       | <ul style="list-style-type: none"> <li>When a section of the track is viewed in the direction of increasing chainage, the left rail is to the left of the centre of the track.</li> </ul>   |
| <b>Superelevation base</b>                                 | <ul style="list-style-type: none"> <li>The nominal distance between the active (internal) faces of the left and right rails.</li> <li>The distance over which the superlevation is applied. This is normally the distance between the centre of the left and right rail.</li> </ul>   |
| <b>Left/Right superelevation</b><br><b>Left/Right cant</b> | <ul style="list-style-type: none"> <li>The superelevation or height difference of each rail with respect to the track centre line, usually expressed in millimetres.</li> <li>If one of the rails is used to rotate the track section or the height of the vertical alignment coincides with the lowest rail, the superelevation of the rotation point or lowest rail will be zero.</li> <li>Superelevation is also known by the term cant. These two words may be interchanged.</li> </ul> |

## 8.3

## Working with Multiple Tracks

### Description

- Multiple tracks are used when more than one track share a common centre line, from which all chainages are calculated.
- In the case of multiple tracks with independent centre lines for each track, each track is then considered as a single track. Refer to "8.2 Working with a Single Track" for details on single tracks.

### Diagram - Plan

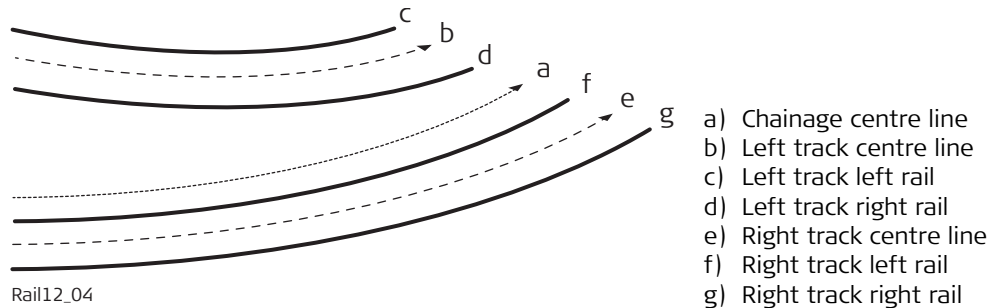

## Diagram - Section

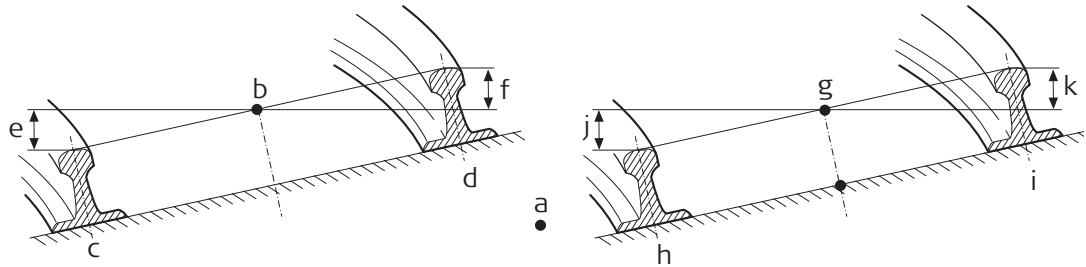

Rail12\_05

- a) Chainage centre line
- b) Left track centre line
- c) Left track left rail
- d) Left track right rail
- e) Left track left rail superelevation
- f) Left track right rail superelevation
- g) Right track centre line
- h) Right track left rail
- i) Right track right rail
- j) Right track left rail superelevation
- k) Right track right rail superelevation

## Calculations

In the case of multiple tracks, the chainage centre line is used only to calculate the chainage, the superelevation of each track is calculated with respect to the corresponding (left / right) vertical alignment. The chainage centre line may consist of a plan and a vertical component, although the vertical component of the chainage centre line is not used for any calculation.

## 8.4

## Rail Check Elements and Rail Stake-Out Elements

### Description

Points may be staked with respect to three basic elements of the track:

- Centre line
- Left rail
- Right rail

### Centre line stakeout

#### Description

The centre line to stake out may be a track centre line or, in the case of multiple tracks, the chainage centre line. In both cases, a horizontal offset with respect to the centre line may be applied. Additionally, if a vertical alignment is available for a track centre line, a vertical offset may be applied.

#### Diagram - single track elements

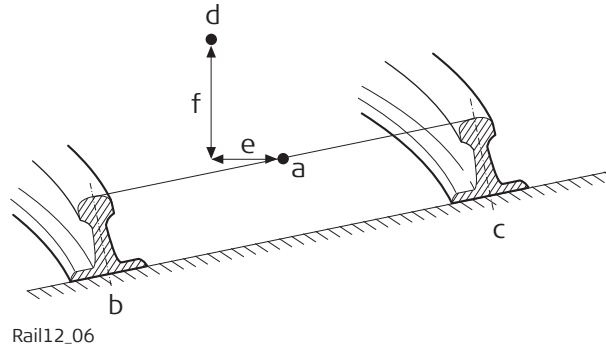

- a) Track Centre line
- b) Left rail
- c) Right rail
- d) Point to stake
- e) Horizontal offset from track centre line
- f) Vertical offset from track centre line

## Left/Right Rail stakeout

### Description

The left or right rail of a track may be staked out:

- directly,
- horizontal and/or vertical offsets may be used to stake any point relative to either rail.

### Diagram - staking out a point relative to the right rail

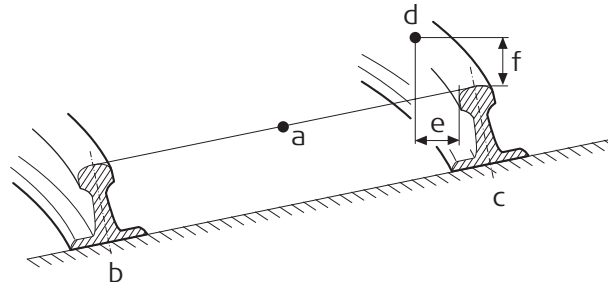

Rail12\_07

- a) Track Centre line
- b) Left rail
- c) Right rail
- d) Point to stake
- e) Horizontal offset from right rail
- f) Vertical offset from right rail



The position from which the horizontal and rail offsets will be applied depends on how the design data that has been imported has defined the left and right rails. Using standard practice, the horizontal offset would be defined from the active face of the rail, whilst the height offset would be defined from the highest part of the rail as shown in the diagram.

## 8.5

### The sign convention for offsets

### Working with Offsets

The sign convention for offsets is:

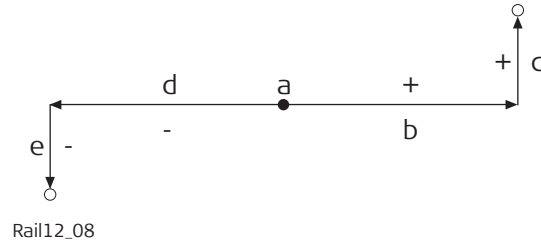

- a) Centre line
- b) Positive horizontal offset
- c) Positive vertical offset
- d) Negative horizontal offset
- e) Negative vertical offset

## 8.6

## Working with Horizontal Shifts and Vertical Shifts

### Description

When working on a construction site, it is often the case that design data does not match the measured data. For example, an existing surface that should intersect with the design surface may be higher or lower than the plans indicate. To allow for this situation, it is possible to add shifts to the existing design data. A shift is applied when selecting the element to stake out/check.



Shifts do not change the stored design.  
The shifts are only temporarily applied during staking or checking.

### Types of horizontal shifts



Types of horizontal shifts:

1. None
2. Constant

Refer to "5.3 Working with the Tasks" for details on selecting the type of horizontal shift.



### Types of vertical shifts

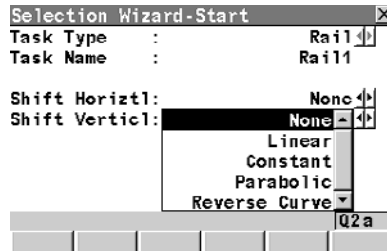

Types of vertical shifts:

1. None
2. Linear
3. Constant
4. Parabolic
5. Reverse Curve

Refer to "5.3 Working with the Tasks" for details on selecting the type of vertical shift.

**An example of a shift:  
centre line shifts**

---

Constant shifts are supported.  
The shift remains the same, from its start chainage/station to its end chainage/station.

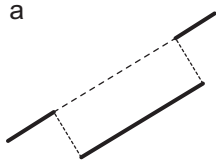

RR12\_014

a) Constant shift

---

**An example of a shift:  
horizontal alignment  
with constant  
horizontal shift**

Horizontal shifts are always perpendicular to the centre line.

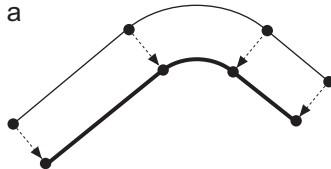

RR12\_013

a) Horizontal alignment with constant shift; plan view

---



**An example of a shift:  
vertical alignment  
with constant  
vertical shift**

Vertical shifts are always applied along the plumb line.

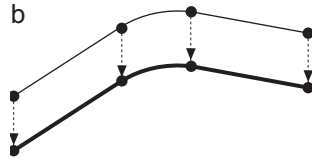

a) Vertical alignment with constant shift; profile view

**The sign convention  
for shifts**

The sign convention for shifts is identical to the sign convention for offsets.

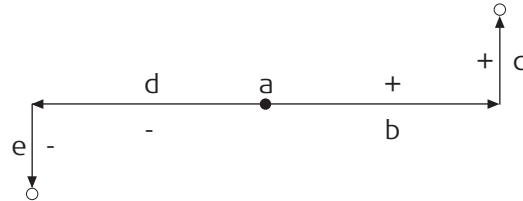

Rail12\_08

- a) Centre line
- b) Positive horizontal shift
- c) Positive vertical shift
- d) Negative horizontal shift
- e) Negative vertical shift

# Index

## A

|                   |     |
|-------------------|-----|
| Auto Positioning  |     |
| Configuring ..... | 91  |
| Definition .....  | 114 |

## C

|                                      |     |
|--------------------------------------|-----|
| Cant Left/Right                      |     |
| Description for Rail Check .....     | 27  |
| Description for Rail Stake-Out ..... | 46  |
| Centre line                          |     |
| Chainage .....                       | 130 |
| Chainage                             |     |
| Centre line .....                    | 130 |
| Format .....                         | 88  |
| Chainage, Definition .....           | 128 |
| Configuring the program              |     |
| Configuring the Check page .....     | 102 |
| Configuring the General page .....   | 93  |
| Configuring the Info&Plot page ..... | 105 |
| Configuring the Logfile page .....   | 113 |
| Configuring the Rail page .....      | 97  |
| Configuring the project              |     |
| Configuring the General page .....   | 88  |
| Configuring the Posit page .....     | 91  |

## D

|                   |   |
|-------------------|---|
| Design to Field   |   |
| Description ..... | 7 |

|                    |    |
|--------------------|----|
| Installing .....   | 7  |
| Display mask ..... | 88 |

## E

|                               |    |
|-------------------------------|----|
| Extras for Rail Check         |    |
| Manual height .....           | 34 |
| Reset heights to design ..... | 34 |
| Second Point of Cant .....    | 34 |
| Extras for Rail Stake-Out     |    |
| Change in chainage .....      | 56 |
| Decrement chainage .....      | 57 |
| Individual point 2D .....     | 57 |
| Manual height .....           | 56 |
| Reset heights to design ..... | 56 |
| Extras Menu                   |    |
| for Rail Check .....          | 34 |
| for Rail Stake-Out .....      | 56 |

## G

|                                     |     |
|-------------------------------------|-----|
| General terms and expressions ..... | 125 |
|-------------------------------------|-----|

## H

|                                  |     |
|----------------------------------|-----|
| Horizontal Shifts                |     |
| Definition .....                 | 135 |
| Types of horizontal shifts ..... | 135 |

## I

|                   |   |
|-------------------|---|
| Importers         |   |
| Description ..... | 7 |

|                                       |     |
|---------------------------------------|-----|
| Installing .....                      | 7   |
| <b>J</b>                              |     |
| Job                                   |     |
| Digital Terrain Model (DTM) job ..... | 61  |
| Fixpoint job .....                    | 60  |
| Measurement job .....                 | 60  |
| Rail job .....                        | 61  |
| Road job .....                        | 60  |
| Tunnel job .....                      | 61  |
| Jobs                                  |     |
| Managing jobs .....                   | 58  |
| Managing the rail job .....           | 68  |
| <b>L</b>                              |     |
| Left rail and Right rail .....        | 128 |
| Leica Geo Office                      |     |
| Installing .....                      | 7   |
| Library Offsets                       |     |
| for Rail Check .....                  | 31  |
| for Rail Stake-Out .....              | 53  |
| Licence key .....                     | 14  |
| <b>M</b>                              |     |
| Managing                              |     |
| Jobs .....                            | 58  |
| Projects .....                        | 58  |
| Manual Offsets                        |     |
| for Rail Check .....                  | 30  |
| for Rail Stake-Out .....              | 52  |

|  |     |
|--|-----|
| <b>N</b>                                     |     |
| Nominal gauge .....                          | 129 |
| <b>O</b>                                     |     |
| Offsets                                      |     |
| Sign convention .....                        | 134 |
| Using offsets with Rail Check .....          | 29  |
| Using offsets with Rail Stake-Out .....      | 51  |
| Offsets with Rail Check                      |     |
| Defining new offsets .....                   | 32  |
| Description .....                            | 29  |
| Library offsets .....                        | 31  |
| Manual offsets .....                         | 30  |
| Offsets with Rail Stake-Out                  |     |
| Defining new offsets .....                   | 54  |
| Description .....                            | 51  |
| Library offsets .....                        | 53  |
| Manual offsets .....                         | 52  |
| <b>P</b>                                     |     |
| Project                                      |     |
| Creating a new project .....                 | 64  |
| Definition .....                             | 59  |
| Deleting an existing project .....           | 67  |
| Editing an existing project .....            | 65  |
| Managing projects .....                      | 58  |
| Selecting a project by browsing a list ..... | 62  |
| Selecting a project by resuming a task ..... | 63  |

|   |        |
|---|--------|
| <b>R</b>  |        |
| Rail Check  |        |
| Check height difference .....                       | 26     |
| Check height of lower rail .....                    | 27     |
| Check offset .....                                  | 26     |
| Checking a track .....                              | 21, 24 |
| Definition .....                                    | 125    |
| Rail Editor   |        |
| Description .....                                   | 7      |
| Installing .....                                    | 7      |
| Using the program .....                             | 120    |
| Rail Stake-Out                                      |        |
| Definition .....                                    | 125    |
| Setting out a track .....                           | 38     |
| Stake height difference .....                       | 45     |
| Stake height of lower rail .....                    | 46     |
| Stake offset .....                                  | 45     |
| Working with a horiz alignment .....                | 45     |
| Working with a horiz/vert alignment .....           | 47     |
| Working with a horiz/vert alignment and super ..... | 48     |
| Right rail and Left rail .....                      | 128    |
| RoadRunner Rail                                     |        |
| Installing .....                                    | 7      |
| <b>S</b>  |        |
| Shift   |        |
| Sign convention .....                               | 137    |
| Shifts  |        |
| Definition of horiz and vert shifts .....           | 135    |
| Types of horizontal shifts .....                    | 135    |
| Types of vertical shifts .....                      | 135    |
| Slope   |        |
| Format .....  | 89     |
| Sign definition .....                               | 89     |
| Stakeout  |        |
| To centre line .....                                | 132    |
| To rail .....                                       | 133    |
| Station, Definition .....                           | 128    |
| Superelevation .....                                | 129    |
| Superelevation base .....                           | 129    |
| <b>T</b>  |        |
| Tasks   |        |
| Setting shifts in the tasks .....                   | 75     |
| Working with tasks .....                            | 71     |
| Terms and Expressions .....                         | 125    |
| Track   |        |
| Centre line .....                                   | 128    |
| Definition .....                                    | 125    |
| Definition of a single track .....                  | 127    |
| Definition of multiple tracks .....                 | 130    |
| <b>V</b>  |        |
| Vertical Shifts                                     |        |
| Definition .....                                    | 135    |
| Types of vertical shifts .....                      | 135    |

**Total Quality Management: Our commitment to total customer satisfaction.**



Leica Geosystems AG, Heerbrugg, Switzerland, has been certified as being equipped with a quality system which meets the International Standards of Quality Management and Quality Systems (ISO standard 9001) and Environmental Management Systems (ISO standard 14001).

**Ask your local Leica Geosystems dealer for more information about our TQM program.**

**Leica Geosystems AG**  
Heinrich-Wild-Strasse  
CH-9435 Heerbrugg  
Switzerland  
Phone +41 71 727 31 31  
[www.leica-geosystems.com](http://www.leica-geosystems.com)

- when it has to be **right**

**Leica**  
**Geosystems**