

TPS1200 Laser Guide GUS74

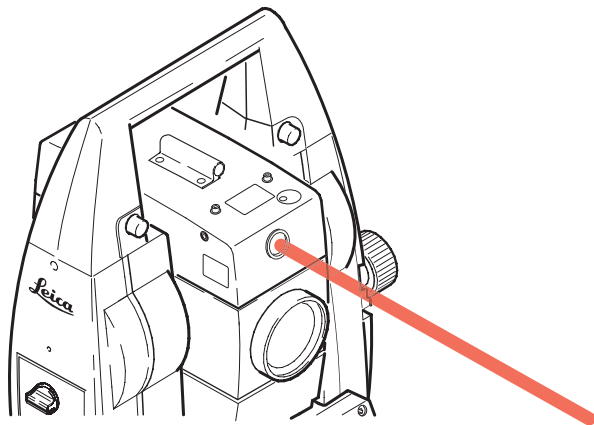

User Manual

Version 1.0
English

Leica
Geosystems

Introduction

Purchase

Congratulations on the purchase of a TPS1200 instrument with Laser Guide GUS74.



This manual contains important safety directions as well as instructions for setting up the product and operating it. Refer to "5 Safety Directions" for further information. Read carefully through this manual before switching on the product.



Refer to "TPS1200 User Manual" for more information and its safety directions. Read this manual carefully to achieve maximum efficiency from the instrument.

Product identification

The model and the serial number of the product are indicated on the type plate. Enter the model and serial number in this manual and always refer to this information when contacting the agency or Leica Geosystems authorized service workshop.

Type: _____

Serial No.: _____

Software-Version: _____

Symbols

The symbols used in this manual have the following meanings:





Type	Description
 Danger	Indicates an imminently hazardous situation which, if not avoided, will result in death or serious injury.
 Warning	Indicates a potentially hazardous situation or an unintended use which, if not avoided, could result in death or serious injury.
 Caution	Indicates a potentially hazardous situation or an unintended use which, if not avoided, may result in minor or moderate injury and/or appreciable material, financial and environmental damage.
	Important paragraphs which must be adhered to in practice as they enable the product to be used in a technically correct and efficient manner.

Table of Contents

In this manual

Chapter	Page
1 How to Use this Manual	1-1
2 Description of the System	2-1
3 Operation	3-1
4 Check & Adjust	4-1
5 Safety Directions	5-1
6 Technical Data	6-1
Index	i-1

1 How to Use this Manual



It is recommended to set-up the product while reading through this manual.

Path

Main Menu: Manage...Data stands for this working sequence:
From the **Main Menu** select **Manage...** and then select **Data**.

Screen

CONFIGURE General Menu describes the name of the screen.

Page

Screens can have more than one page. **Units** page describes a specific page of a screen. For example: '...in **CONFIGURE Units and Formats, Units** page...'

Index

The index is at the back of the manual.



Keys, fields and options on the screens which are considered as self-explanatory are not explained.

Validity of this manual

This manual applies to all TPS1200 instruments with Laser Guide GUS74.

2 Description of the System

Description

The Laser Guide GUS74 is an option for TPS1200 instruments equipped with ATR. Instruments equipped with the Laser Guide cannot be equipped with PowerSearch or EGL.

The Laser Guide is included in a special compartment in the upper telescope section.

The Laser Guide emits a visible red laser beam used for visualizing the line of sight.

Use

- Guiding tunnel boring machines, monitoring tunneling progress or visualizing bore holes for rock blasting.
 - Targeting of inaccessible objects or prohibited surfaces.
 - Positioning of objects and inspecting marks on surfaces.
-

Laser Guide components

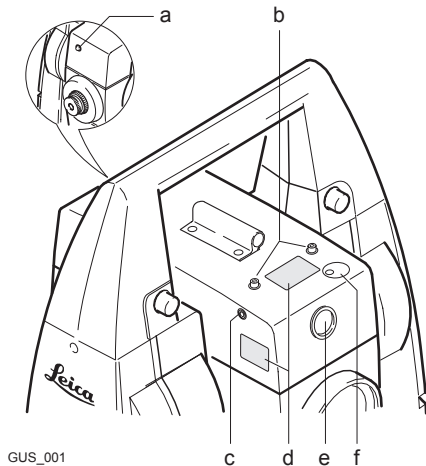

- a) Operation indicator LED, orange
- b) Fixing screws
- c) Horizontal adjustment screws
- d) Labelling
- e) Laser aperture
- f) Safety cover for vertical adjustment screws



Two allen keys 2.5 and one allen key 2.0 are also included in the container.

3 Operation

In this chapter

	Topic	Page
3.1	Overview	3-2
3.2	Manual Operation	3-3
3.3	Operation via Serial Interface	3-5
3.4	Trouble Shooting	3-6

3.1 Overview

Description

The Laser Guide GUS74 can be operated and configured manually or via the serial RS232 interface of the TPS1200 instrument.



The Laser Guide will be automatically turned off temporarily during distance measurement.



For instruments equipped with reflectorless EDM (RL) the Laser Guide will be automatically turned off when the reflectorless laser pointer is turned on.

3.2 Manual Operation

Description

The Laser Guide can be turned on or off manually and its intensity can be regulated in steps of 10%.

Access

Select **Main Menu: Config...\General Settings...\Lights, Display, Beeps, Text.**

OR

Press **SHIFT F11.**

CONFIGURE Lights, Display, Beeps, Text, Lights page

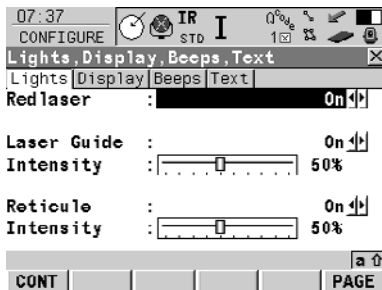

CONT (F1)

To accept changes and return to the screen from where this screen was accessed.

Description of fields

Field	Option	Description
<Laser Guide:>	On or Off	Turns the Laser Guide immediately on and off.
<Intensity:>	From 0% to 100%	Adjusts the Laser Guide intensity immediately using the left and right arrow keys.

3.3 Operation via Serial Interface

Description

By sending GeoCOM commands to the serial interface RS232 of the TPS1200 instrument the Laser Guide can be turned on or off and its intensity can be regulated in steps of 10%.



To operate the Laser Guide via serial interface the GeoCOM communication settings of the TPS1200 and the communication settings of the interfacing system must be identical.



Refer to the "TPS1200 GeoCOM Reference Manual" for further information on GeoCOM.

GeoCOM commands

Command: **%R1Q,1069:'XX'<CR/LF>**

XX = 00 turns the Laser Guide off.

XX = 04 turns the Laser Guide on with 40% intensity.

XX = 0a... turns the Laser Guide on with 100% intensity or changes intensity to 100% if the Laser Guide is already turned on.

Response: **%R1P,0,0:0**

3.4 Trouble Shooting

Laser Guide operation

Problem	Details / To be checked
Response: %R1P,0,0:308x is received via serial interface	The command sent was not understood by the TPS1200 instrument. Check the following: <ul style="list-style-type: none">• GeoCOM command and syntax• RS232 GeoCOM communication settings on the TPS1200• Communication settings on the interfacing system• RS232 cable connection
The screen CONFIGURE Lights, Display, Beeps, Text does not contain the fields <Laser Guide> and <Intensity> .	The TPS1200 is not equipped with a Laser Guide or the Laser Guide is defective. Contact the Leica Geosystems authorized service workshop.

Problem	Details / To be checked
Operation via serial interface not possible	<p>The TPS1200 is not equipped with a Laser Guide or the Laser Guide may be defective. Send the following GeoCOM command to the TPS1200:</p> <p>Command: %R1Q,1062: <CR/LF></p> <p>Response: %R1P,X,1</p> <p>X = 0 The Laser Guide is correctly set and operable.</p> <p>X ≠ 0 The TPS1200 is not equipped with a Laser Guide or the Laser Guide may be defective.</p> <p>Contact the Leica Geosystems authorized service workshop.</p>

4 Check & Adjust

General

When transporting or shipping the equipment always use the complete original Leica Geosystems packaging, transport container and cardboard box.



After long periods of storage or transport inspect the field adjustment parameters given in this user manual before using the product.



To avoid moisture or dust entering the Laser Guide compartment, adjustment screws and screw covers must be fixed after each adjustment procedure.

Adjustment

The recommended adjustment procedure is designed for distances of 50 m and 120 m. Use the adjustment drawing, which is showing a TPS1200 telescope, with crosshairs for line of sight and Laser Guide. Look through the telescope and aim to the telescope's crosshairs. For well-adjusted Laser Guides, the laser beam should exactly match the circles for 50/120 m.



Make sure, adjustment screws are accessible during adjustment.



Make sure, the telescope's position remains still. Check the target by looking through the telescope.



Adjustment procedure might be repeated to achieve high precision adjustment.

Target plate

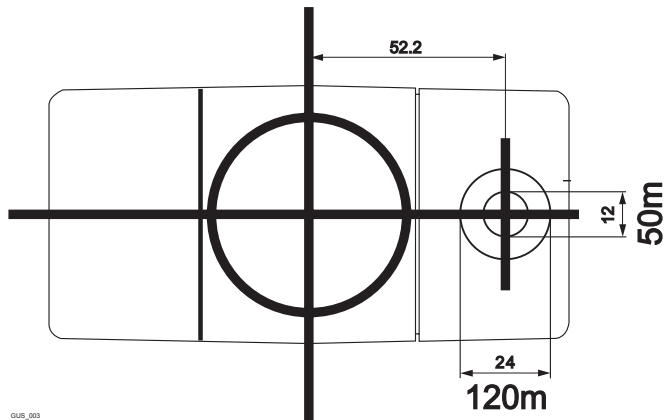

Please enlarge this target plate to 200% prior to using it for adjustment.

Diagram

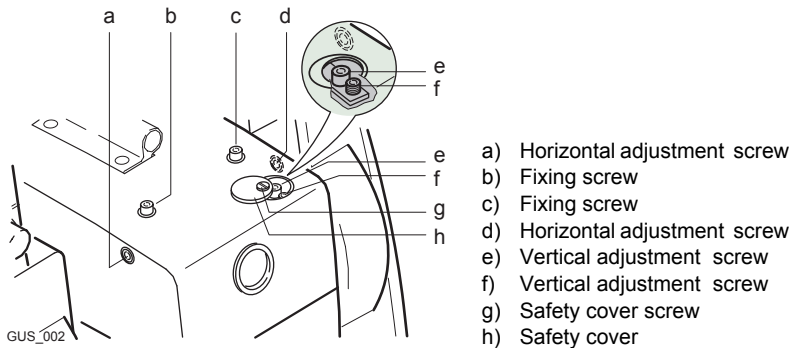



Laser Guide adjustment step-by-step

This step-by-step description describes the Laser Guide adjustment for a distance of 50 m. Place the target plate at a distance of 120 m to perform the laser guide adjustment for 120 m.

Step	Description
	Make sure the instrument is leveled.
1.	Place the laser guide target plate at a distance of 50 m and aim with the telescope of the instrument at the crosshairs of the target plate.

Step	Description
2.	Loosen the safety cover screw (g) and move the safety cover (h) to the side to access the vertical adjustment screws.
3.	Loosen the vertical adjustment screws (e) and (f). Do not fully remove the screws.
4.	Loosen the fixing screws (b) and (c) as little as the spring force remains.
5.	<p>Horizontal adjustment:</p> <p>To adjust the laser guide to the left, loosen the horizontal adjustment screw (d). Tighten the horizontal adjustment screw (a) as much as to move the laser beam slightly left of the upper crosshairs on the target plate.</p>
6.	To adjust the laser guide to the right, loosen the horizontal adjustment screw (a). Tighten the horizontal adjustment screw (d) as much as to move the laser beam slightly right of the upper crosshairs on the target plate.
7.	<p>Fix the horizontal adjustment by tightening the opposite horizontal adjustment screw either (a) or (d).</p> <p> Fixing the opposite screw will move the laser beam exactly to the vertical crosshair.</p>
8.	Finish the horizontal adjustment by tightening the fixing screws (b) and (c).

Step	Description
9.	Vertical adjustment: Loosen the vertical adjustment screw (e) as much as to move the laser beam slightly upon of the upper crosshairs on the target plate.
10.	 Fix the vertical adjustment by tightening the vertical adjustment screw (f). Fixing this screw will move the laser beam exactly to the crosshairs center.
11.	Finish the vertical adjustment by moving the safety cover (h) to its original position and by tightening the safety cover screw (g).
	The laser beam of a well adjusted laser guide matches exactly the circle of 50 m or 120 m depending on the distance.

5 Safety Directions

In this chapter

	Topic	Page
5.1	General	5-2
5.2	Intended Use	5-3
5.3	Limits of Use	5-5
5.4	Responsibilities	5-6
5.5	Hazards of Use	5-7
5.6	Laser Classification	5-8
5.7	Electromagnetic Compatibility EMC	5-14
5.8	FCC Statement, Applicable in U.S.	5-16

5.1 General

Description

The following directions should enable the person responsible for the product, and the person who actually uses the equipment, to anticipate and avoid operational hazards.

The person responsible for the product must ensure that all users understand these directions and adhere to them.

Warning

Only Leica Geosystems authorized service workshops are entitled to repair these products.

5.2 Intended Use

Permitted use

- Visualizing the line of sight with the Laser Guide GUS74.
-

Adverse use

- Use of the product without instruction.
- Use outside of the intended limits.
- Disabling safety systems.
- Removal of hazard notices.
- Opening the product using tools, for example screwdriver, unless this is specifically permitted for certain functions.
- Modification or conversion of the product.
- Use after misappropriation.
- Use of products with obviously recognizable damages or defects.
- Use with accessories from other manufacturers without the prior explicit approval of Leica Geosystems.
- Aiming directly into the sun.
- Inadequate safeguards at the surveying site, for example when measuring on roads.
- Deliberate dazzling of third parties.

- Controlling of machines, moving objects or similar monitoring application without additional control and safety installations.

 **Warning**

Adverse use can lead to injury, malfunction and damage.

It is the task of the person responsible for the equipment to inform the user about hazards and how to counteract them. The product is not to be operated until the user has been instructed on how to work with it.

5.3 Limits of Use

Environment

Suitable for use in an atmosphere appropriate for permanent human habitation: Not suitable for use in aggressive or explosive environments.



Danger

Local safety authorities and safety experts must be contacted before working in hazardous explosive areas, in close proximity to electrical installations or similar situations by the person in charge of the product.

5.4 Responsibilities

Manufacturer of the product

Leica Geosystems AG, CH-9435 Heerbrugg, hereinafter referred to as Leica Geosystems, is responsible for supplying the product, including the user manual and original accessories, in a completely safe condition.

Manufacturers of non Leica Geosystems accessories

The manufacturers of non Leica Geosystems accessories for the product are responsible for developing, implementing and communicating safety concepts for their products, and are also responsible for the effectiveness of those safety concepts in combination with the Leica Geosystems product.

Person in charge of the product

The person in charge of the product has the following duties:

- To understand the safety instructions of the product and the instructions in the user manual.
- To be familiar with local regulations relating to safety and accident prevention.
- To inform Leica Geosystems immediately if the product and the application becomes unsafe.



The person responsible for the product must ensure that it is used in accordance with the instructions. This person is also accountable for the training and the deployment of personnel who use the product and for the safety of the equipment in use.

5.5 Hazards of Use

Warning

The absence of instruction, or the inadequate imparting of instruction, can lead to incorrect or adverse use, and can give rise to accidents with far-reaching human, material, financial and environmental consequences.

Precautions:

All users must follow the safety directions given by the manufacturer and the directions of the person responsible for the product.

Caution

Watch out for erroneous measurement results if the product has been dropped or has been misused, modified, stored for long periods or transported.

Precautions:

Periodically carry out test measurements and perform the field adjustments indicated in the user manual, particularly after the product has been subjected to abnormal use and before and after important measurements.

5.6 Laser Classification

General

The Laser Guide built into the TPS1200 instrument produces a visible, red laser beam, which emerges from the front section of the telescope.

The product is a class 3R laser product in accordance with:

- IEC 60825-1 (2001-08) : "Safety of Laser Products"
- EN 60825-1:1994 + A11:1996 + A2:2001 : "Safety of Laser Products"

Class 3R laser products:

Direct intrabeam viewing is always hazardous. Avoid direct eye exposure. The accessible emission limit is within five times the accessible emission limits of class 2 in the wavelength range from 400 nm to 700 nm.

Description	Value
Maximum radiant power	4.75 mW
Maximum radiant power per pulse	n/a
Pulse duration	c.w.
Beam divergence	0.162 mrad
Measurement uncertainty	± 5%

 **Warning**

Direct intrabeam viewing is always hazardous.

Precautions:

Do not stare into the beam or direct it towards other people unnecessarily. These measures are also valid for the reflected beam.

 **Warning**

Looking directly into the reflected laser beam could be dangerous to the eyes when the laser beam is aimed at areas that reflect like a mirror or emit reflections unexpectedly, for example prisms, mirrors, metallic surfaces or windows.

Precautions:

Do not aim at areas that are essentially reflective, such as a mirror, or which could emit unwanted reflections.

Do not look through or beside the optical sight at prisms or reflecting objects when the laser is switched on, in laserpointer or distance measurement mode. Aiming at prisms is only permitted when looking through the telescope.

 **Warning**

In remote controlled systems the laser beam can be moved automatically via serial interface commands without direct control of the user.

Precautions:

Check carefully if the laser beam is automatically turned off at beam movements of more than approximately 5° in horizontal or vertical direction to counteract hazards.

 **Warning**

The use of laser class 3R equipment can be dangerous.

Precautions:

To counteract hazards, it is essential for every user to respect the safety precautions and control measures specified in the standard IEC 60825-1 (2001-08) resp. EN 60825-1:1994 + A11:1996 + A2:2001, within the hazard distance *).

Following an interpretation of the main points in the relevant section of the standard quoted.

Class 3R laser products used on construction sites and outdoors, for example surveying, alignment, levelling:

- a) Only qualified and trained persons should be assigned to install, adjust and operate the laser equipment.
- b) Areas in which these lasers are used should be posted with an appropriate laser warning sign.
- c) Precautions should be taken to ensure that persons do not look directly, with or without an optical instrument, into the beam.
- d) The laser beam should be terminated at the end of its useful beam path and should in all cases be terminated if the hazardous beam path (hazard distance *) extends beyond the limit of the area in which the presence and activities of personnel are monitored for reasons of protection from laser radiation.

- e) The laser beam path should be located well above or below eye level wherever practicable.
- f) When not in use the laser product should be stored in a location where unauthorized personnel cannot gain access.
- g) Precautions should be taken to ensure that the laser beam is not unintentionally directed at mirror-like, specular surfaces for example mirrors, metal surfaces or windows. But, more importantly, at flat or concave mirror-like surfaces.

- *) The hazard distance is the distance from the laser at which beam irradiance or radiant exposure equals the maximum permissible value to which personnel may be exposed without being exposed to a health risk.

Products with an integrated Laser Guide of laser class 3R this hazard distance is 128 m / 420 ft. At this distance, the laser beam rates as class 1, that means direct intrabeam viewing is not hazardous.

Labelling

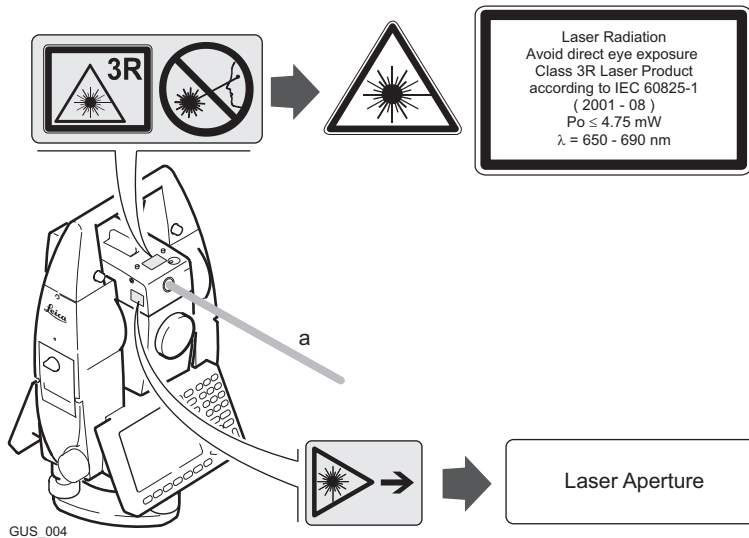

a) Laser beam

Type: TC....
GUS74
Art.No.:
.....

Equip.No.:

Power: 12V/7.2V $\overline{\text{---}}$, 1A max

Leica Geosystems AG
CH-9435 Heerbrugg

Manufactured: 2003
Made in Switzerland

S.No.:
.....



Complies with 21 CFR 1040.10 and 1040.11 except for deviations pursuant to Laser Notice No.50, dated July 26, 2001.

*This device complies with part 15 of the FCC Rules. Operation is subject to the following two conditions:
(1) This device may not cause harmful interference.
(2) This device must accept any interference received, including interference that may cause undesired operation.*

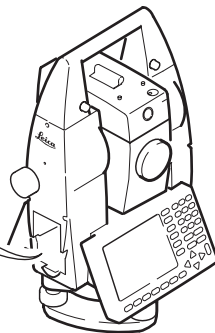

GUS_005

5.7 Electromagnetic Compatibility EMC

Description

The term Electromagnetic Compatibility is taken to mean the capability of the product to function smoothly in an environment where electromagnetic radiation and electrostatic discharges are present, and without causing electromagnetic disturbances to other equipment.

Warning

Electromagnetic radiation can cause disturbances in other equipment.

Although the product meets the strict regulations and standards which are in force in this respect, Leica Geosystems cannot completely exclude the possibility that other equipment may be disturbed.

Caution

There is a risk that disturbances may be caused in other equipment if the product is used in conjunction with accessories from other manufacturers, for example field computers, personal computers, two-way radios, non-standard cables or external batteries.

Precautions:

Use only the equipment and accessories recommended by Leica Geosystems. When combined with the product, they meet the strict requirements stipulated by the guidelines and standards. When using computers and two-way radios, pay attention to the information about electromagnetic compatibility provided by the manufacturer.

 **Caution**

Disturbances caused by electromagnetic radiation can result in erroneous measurements.

Although the product meets the strict regulations and standards which are in force in this respect, Leica Geosystems cannot completely exclude the possibility that the product may be disturbed by very intense electromagnetic radiation, for example, near radio transmitters, two-way radios or diesel generators.

Precautions:

Check the plausibility of results obtained under these conditions.

 **Warning**

If the product is operated with connecting cables attached at only one of their two ends, for example external supply cables, interface cables, the permitted level of electromagnetic radiation may be exceeded and the correct functioning of other products may be impaired.

Precautions:

While the product is in use, connecting cables, for example product to external battery, product to computer, must be connected at both ends.

5.8 FCC Statement, Applicable in U.S.

Warning

This equipment has been tested and found to comply with the limits for a Class B digital device, pursuant to part 15 of the FCC rules.

These limits are designed to provide reasonable protection against harmful interference in a residential installation.

This equipment generates, uses and can radiate frequency energy and, if not installed and used in accordance with the instructions, may cause harmful interference to radio communications.

However, there is no guarantee that interference will not occur in a particular installation.

If this equipment does cause harmful interference to radio or television reception, which can be determined by turning the equipment off and on, the user is encouraged to try to correct the interference by one or more of the following measures:

- Reorient or relocate the receiving antenna.
 - Increase the separation between the equipment and the receiver.
 - Connect the equipment into an outlet on a circuit different from that to which the receiver is connected.
 - Consult the dealer or an experienced radio/TV technician for help.
-

6 Technical Data

Concept	<ul style="list-style-type: none">• Telescope for dual face measurement• User adjustment for laser beam
Laser	Type: visible, red, laser class 3R Carrier wave: 655 nm
Optics	Line of sight offset: 52.20 mm Focussing distance: 22.76 mm Beam angle: 0.09 mrad
Power	Power supply: from instrument Power consumption: ca. 0.2 W
Environmental specifications	Operating temperature range: -20 °C to +50 °C Storage temperature range: -40 °C to +70 °C
Range	Daylight: 250 m Darkness: 500 m

Beam diameter

The laser beam diameter is influenced by the intensity of the laser guide, by the application distance, by the characteristics of the surface and by the ambient light.

Typical GUS74 beam diameter on white, smooth surfaces with intensity 50% and 100%

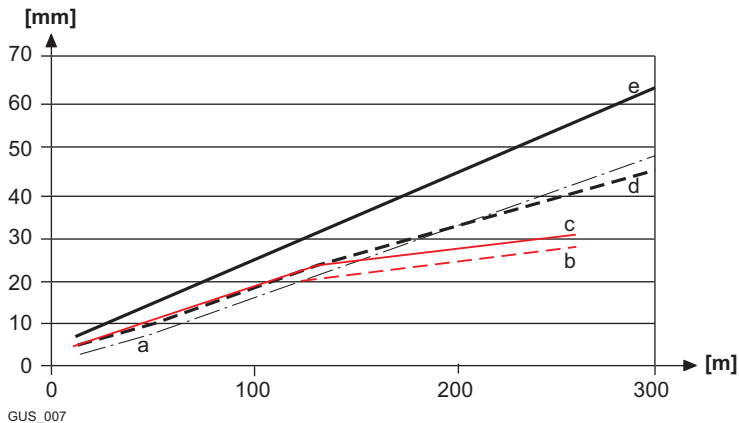

- a) Theoretical $1/e^2$
- b) Daylight, intensity 50%
- c) Daylight, intensity 100%
- d) Darkness, intensity 50%
- e) Darkness, intensity 100%

[m] Distance

[mm] Diameter

Index

A		
Adjustment	4-1	
E		
Electromagnetic Compatibility	5-14	
F		
FCC Statement	5-16	
H		
Hazards of Use	5-7	
Horizontal adjustment	4-4	
I		
Intended Use	5-3	
L		
Laser Classification	5-8	
Laser Guide	2-1	
Laser Guide components	2-2	
Limits of Use		5-5
M		
Manual Operation		3-3
O		
Operation via Serial Interface		3-5
R		
Responsibilities		5-6
S		
Safety Directions		5-1
T		
Technical Data		6-1
Trouble Shooting		3-6
V		
Vertical adjustment		4-5

**Leica Geosystems AG,
Heerbrugg, Switzerland, has
been certified as being
equipped with a quality system
which meets the International
Standards of Quality
Management and Quality
Systems (ISO standard 9001)
and Environmental
Management Systems (ISO
standard 14001).**



**Total Quality Management -
Our commitment to total
customer satisfaction.**

Ask the local Leica Geosystems
agent for more information about our
TQM program.

734583-1.0.0en

Printed in Switzerland - Copyright Leica Geosystems AG, Heerbrugg,
Switzerland 2004
Original text

Leica
Geosystems

Leica Geosystems AG
CH-9435 Heerbrugg
(Switzerland)
Phone +41 71 727 31 31
Fax +41 71 727 46 73
www.leica-geosystems.com